

Aufmaßblatt AsyFlex NF

Laibungsmaß (Bestellbreite)

Form 7

Kommission:

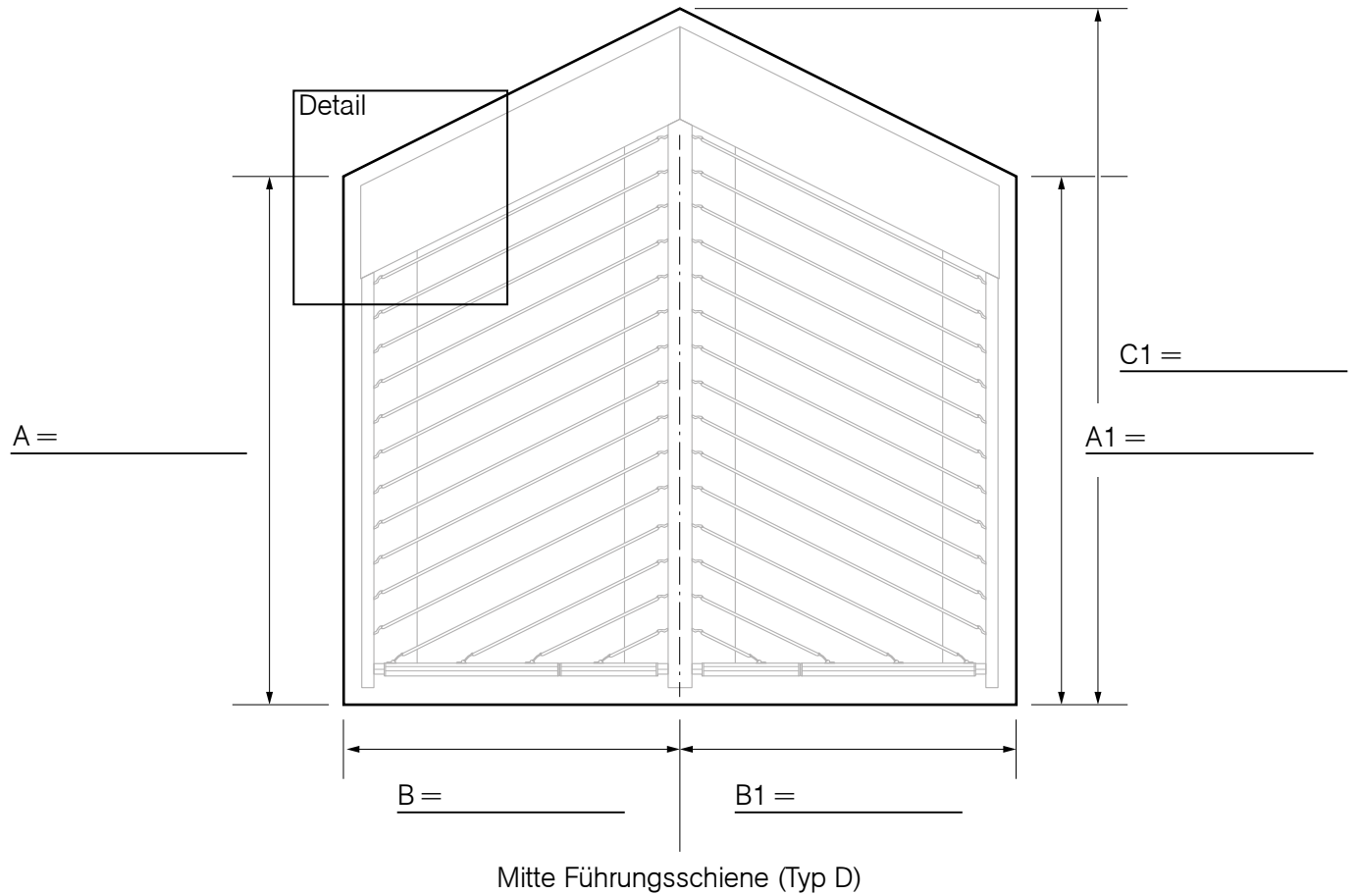

Detail zur Maßermittlung der Bestellbreite

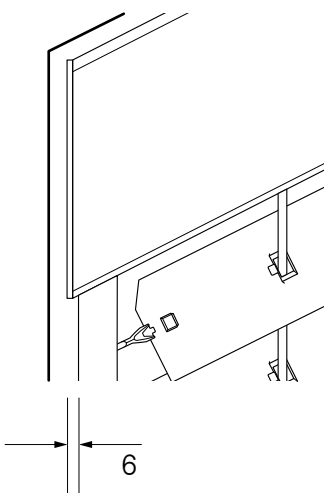

Führungsschiene Typ T

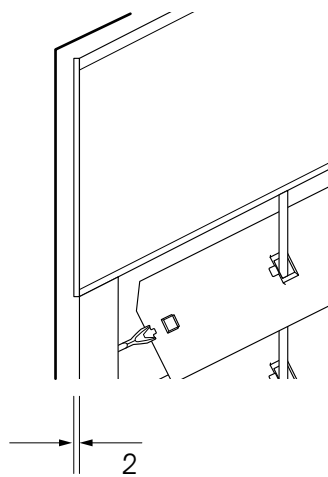

Führungsschiene Typ S70/E30

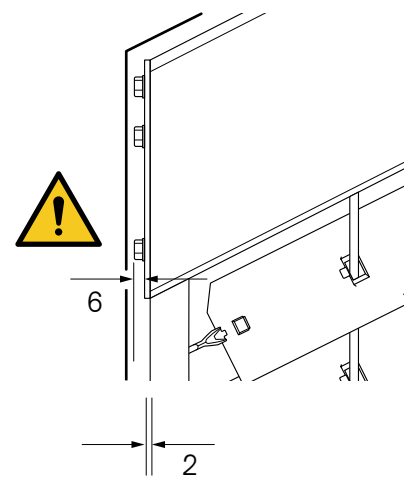

Freitragende Ausführung
Achtung: Schrauben stehen über!