

Hinweise Elektro

Anschluss der Steckerkupplung

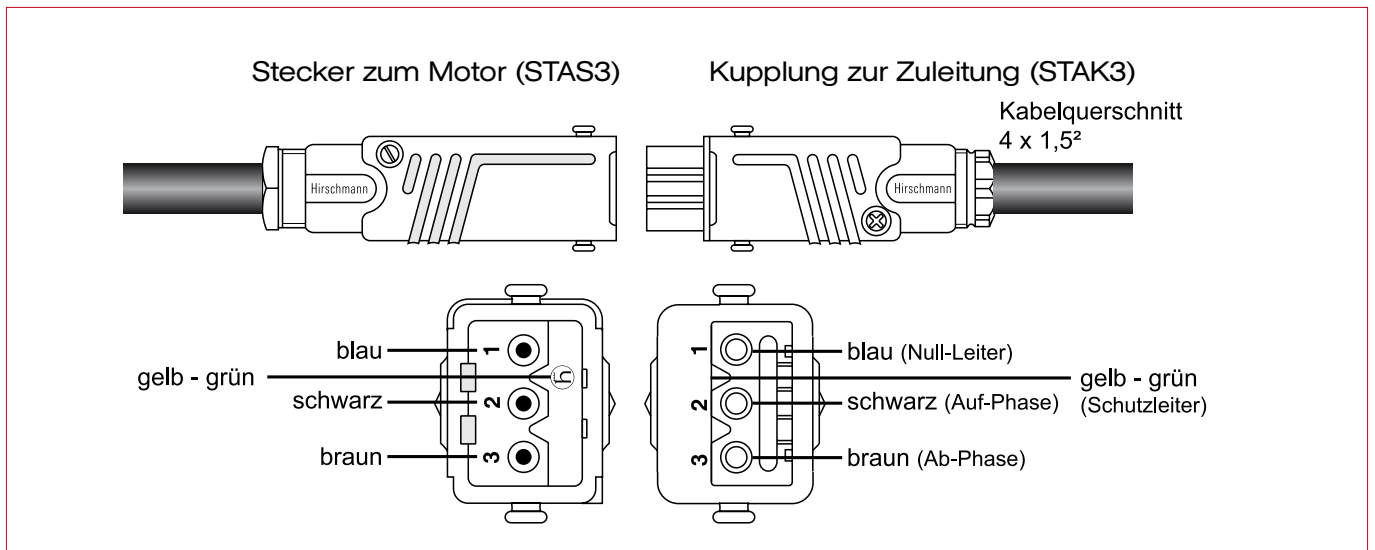

Schaltplan für einpolige Schalter

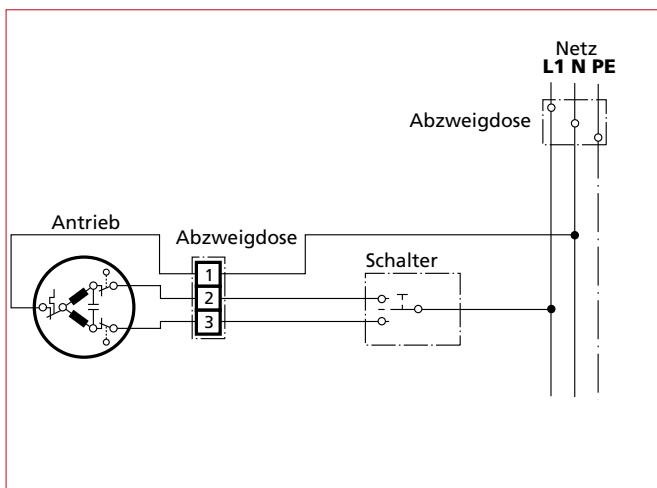

Schaltplan für zweipolige Schalter

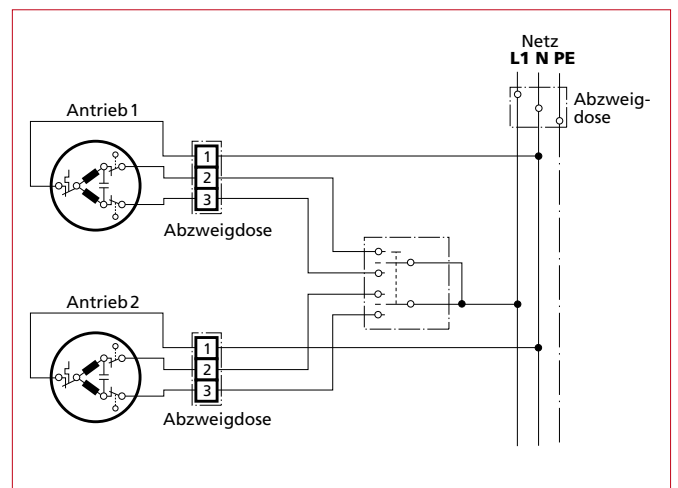

Anschluss des Moduls Slim Receiver

