

Montageanleitung

Raffstore K 71N mit Kurbelantrieb und Führungsschienen



Die Montage ist ausschließlich durch qualifiziertes Fachpersonal auszuführen!





Montage vorbereiten



**Bei der Montage ist darauf zu achten, dass die
Auswahl des Befestigungsmaterials
in Abstimmung mit dem
jeweiligen Montageuntergrund erfolgt.**

Benötigte Werkzeuge

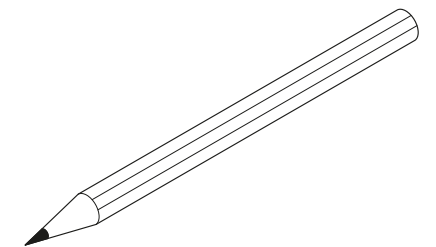
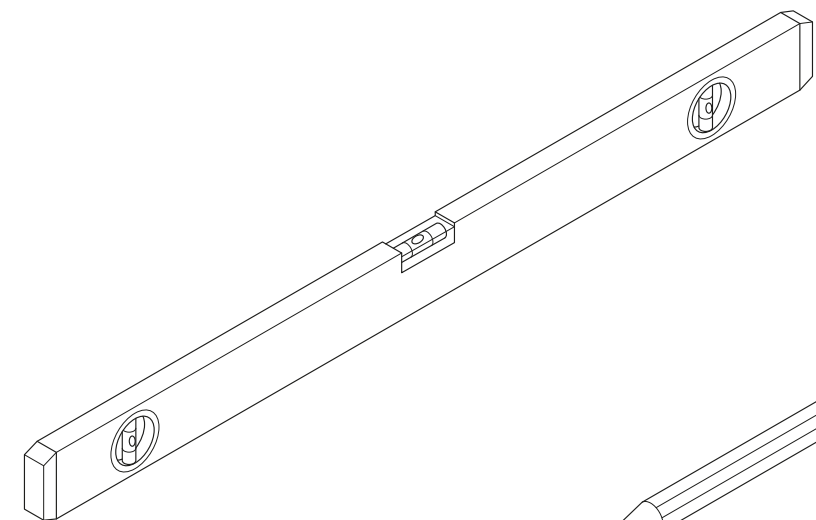
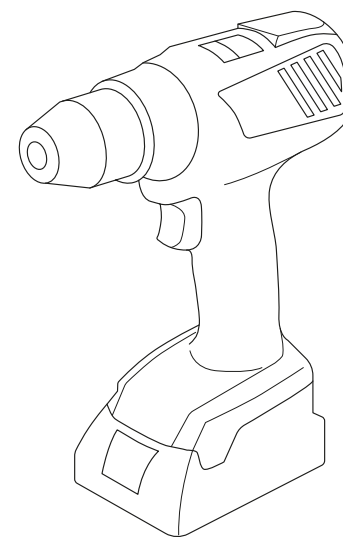
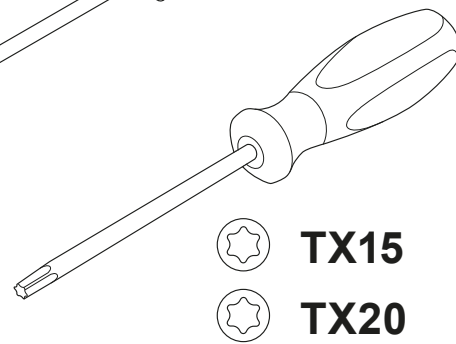
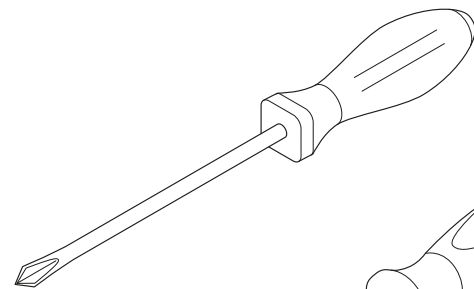
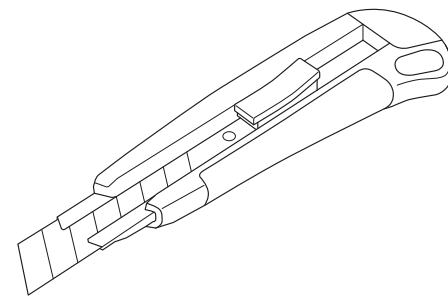
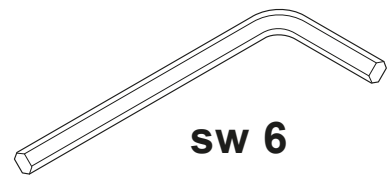
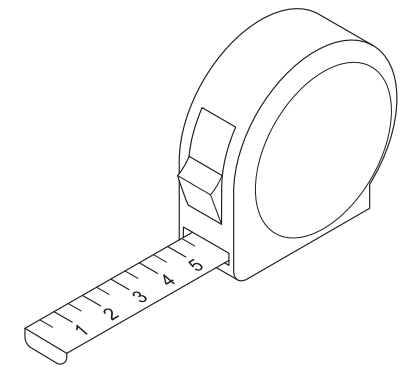
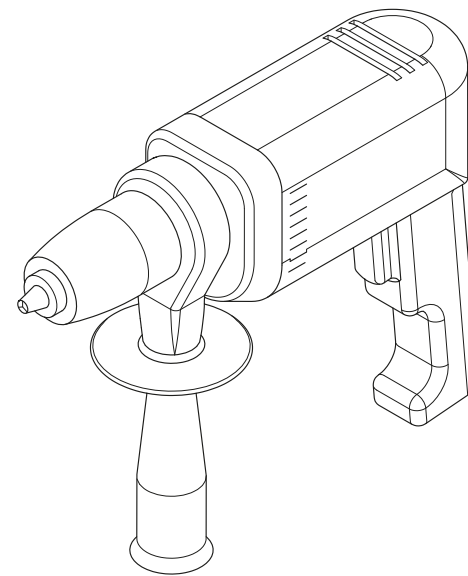
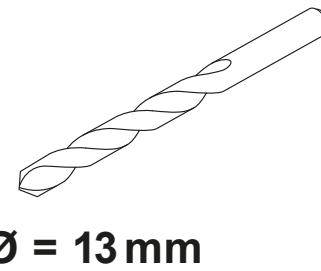
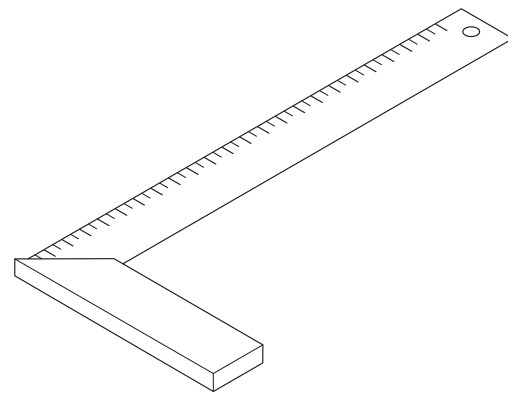
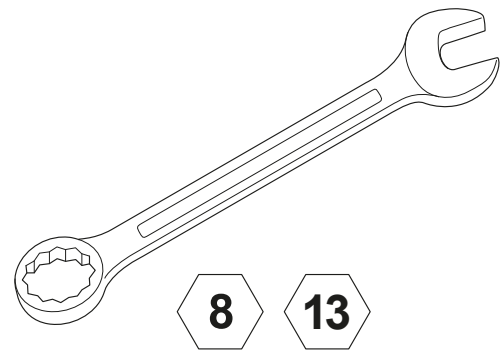

Lieferumfang

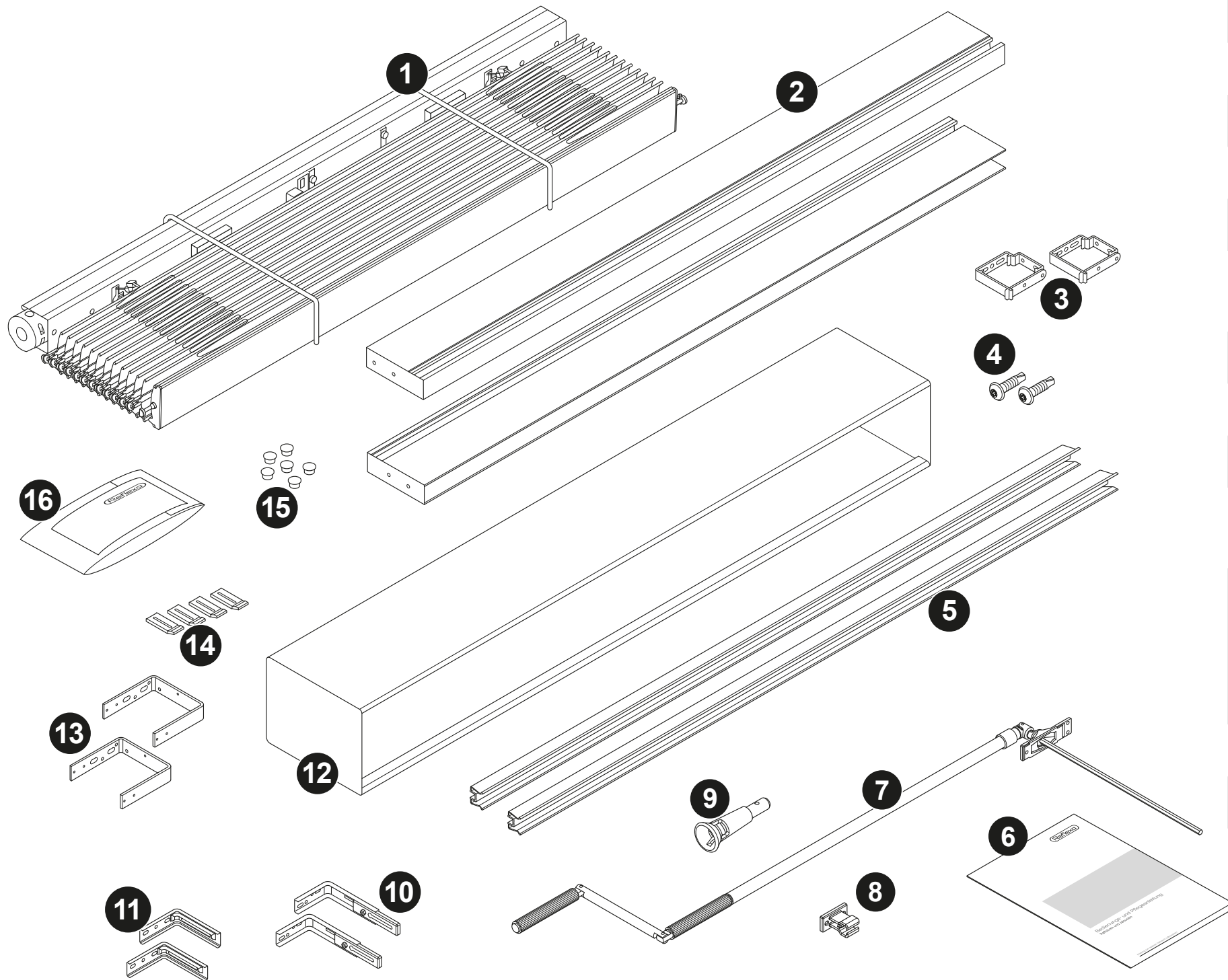

Nr.	Bezeichnung	
1	Raffstorepaket	
2	Führungsschiene mit Clipsprofil	
3	Oberschienenenträger	
4	Sicherungsschraube	optional
5	Montageprofil	optional
6	Bedienungs- und Pflegeanleitung	
7	Kurbelstange mit Knickkurbel und Gelenklager	
8	Kurbelhalter	
9	abnehmbarer Trichter	optional
10	Trägerkonsole KT	optional
11	Trägerkonsole KT mit Schlitten	optional
12	Blende (Form U/W)	
13	Versteifungsbügel	optional
14	Verlängerungsstück	
15	Abdeckkappe	optional
16	Montageset(s)	optional

Montageset 43000413, 43000416 und 43000417 (optional)

43000413

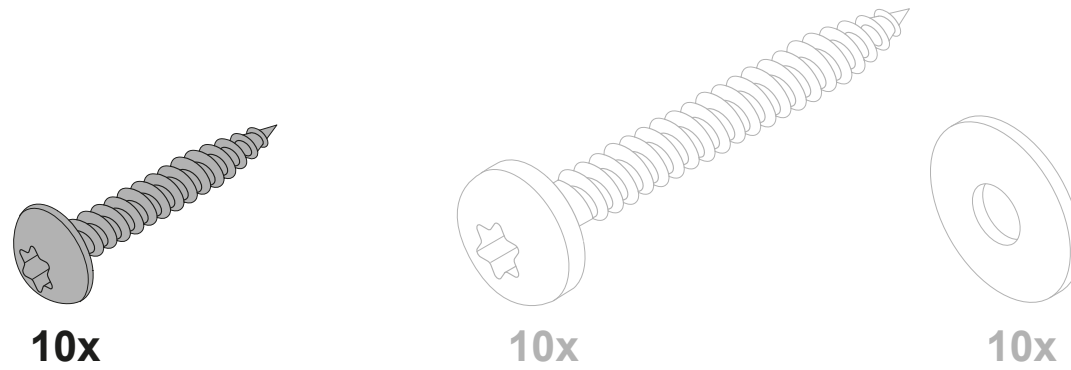

43000416

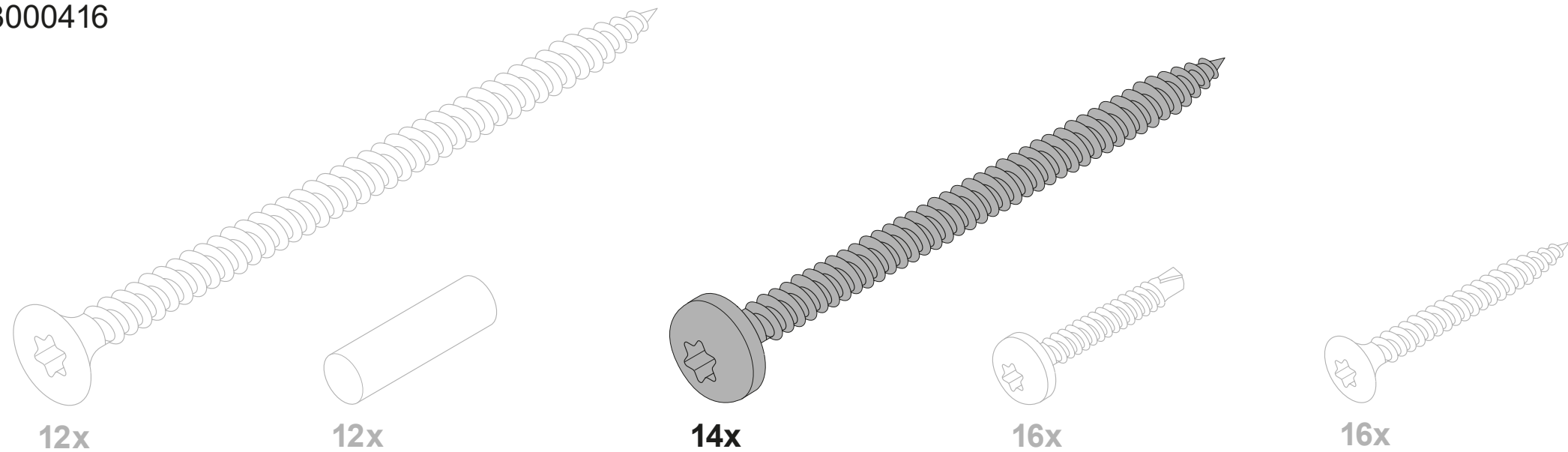

43000417

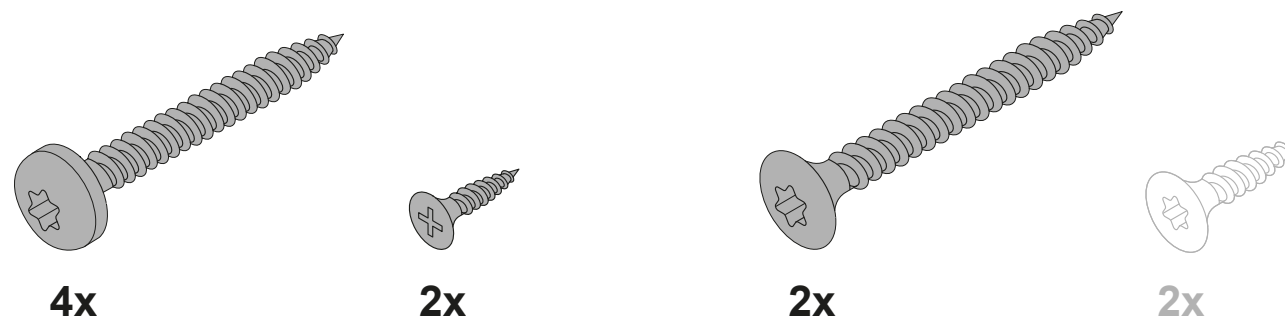

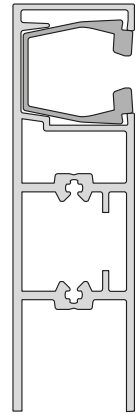

Typ S70
mit Clipsprofil

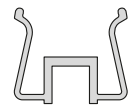

Montageprofil

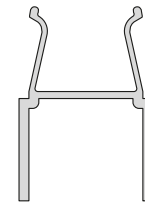

Distanzprofil 20

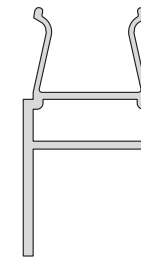

Distanzprofil 30

Anzahl der Oberschiententräger im Verhältnis zur Anlagenbreite

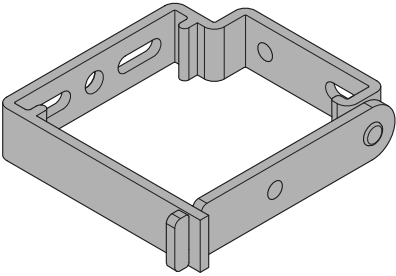
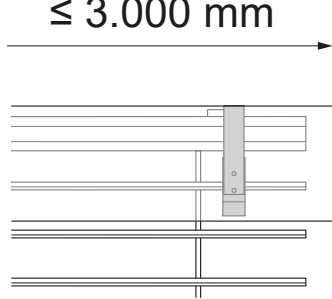
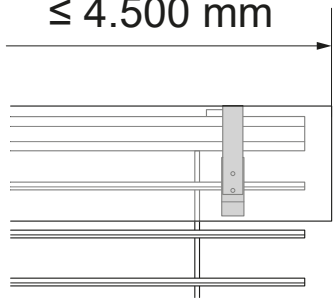
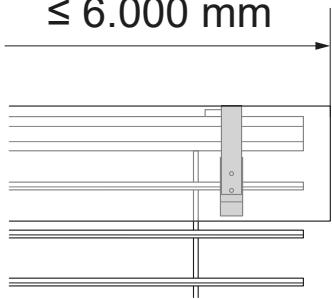
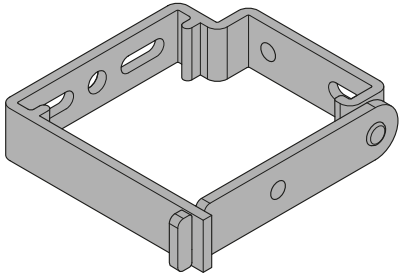
	 $\leq 1.500 \text{ mm}$	 $\leq 3.000 \text{ mm}$	 $\leq 4.500 \text{ mm}$	 $\leq 6.000 \text{ mm}$
	2 x	3 x	4 x	5 x

Maßbezüge der Trägerelemente



Bei mehr als zwei Trägern diese ausmitteln, jedoch mind. 85 mm neben einer Bandspule.

K 71N		
Lamellenlänge (in mm)	≤ 740	> 740
Maß B (in mm)	80	100

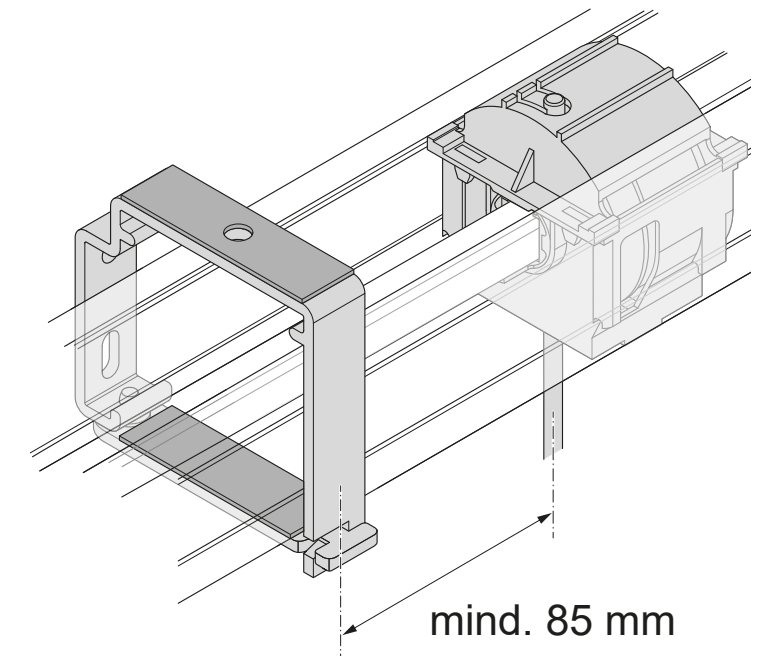
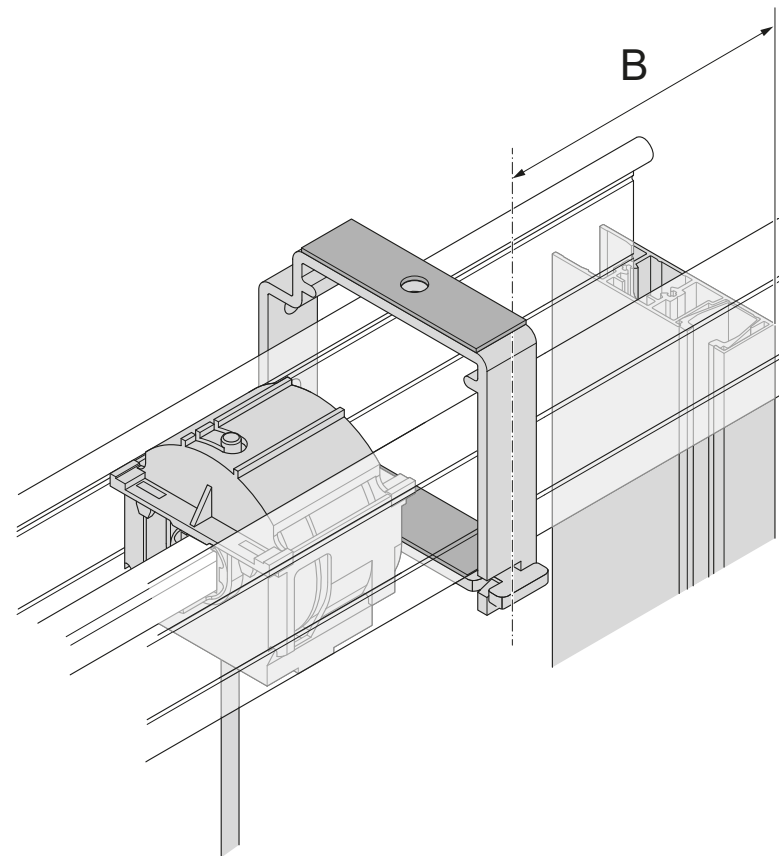
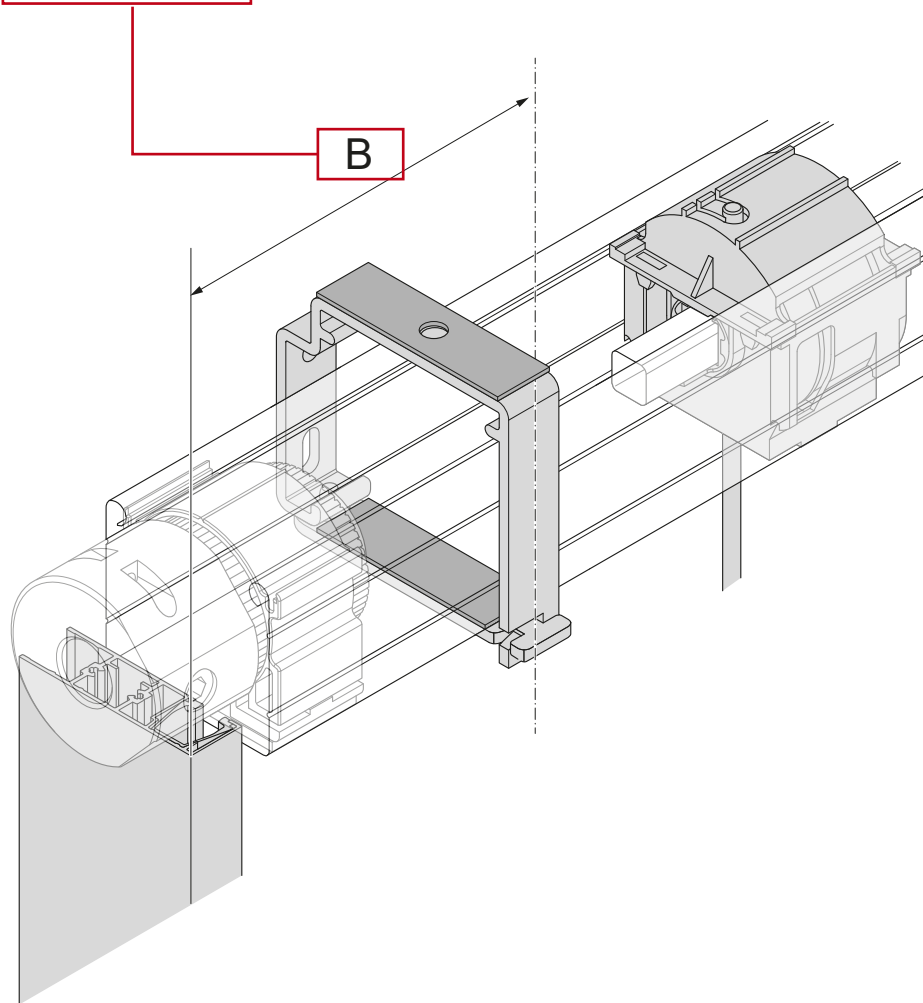



Das „X-Maß“ beschreibt den Abstand zwischen Montageuntergrund und der Mitte des Raffstorepaketes. Je nach Ausführung kann das Maß variieren.

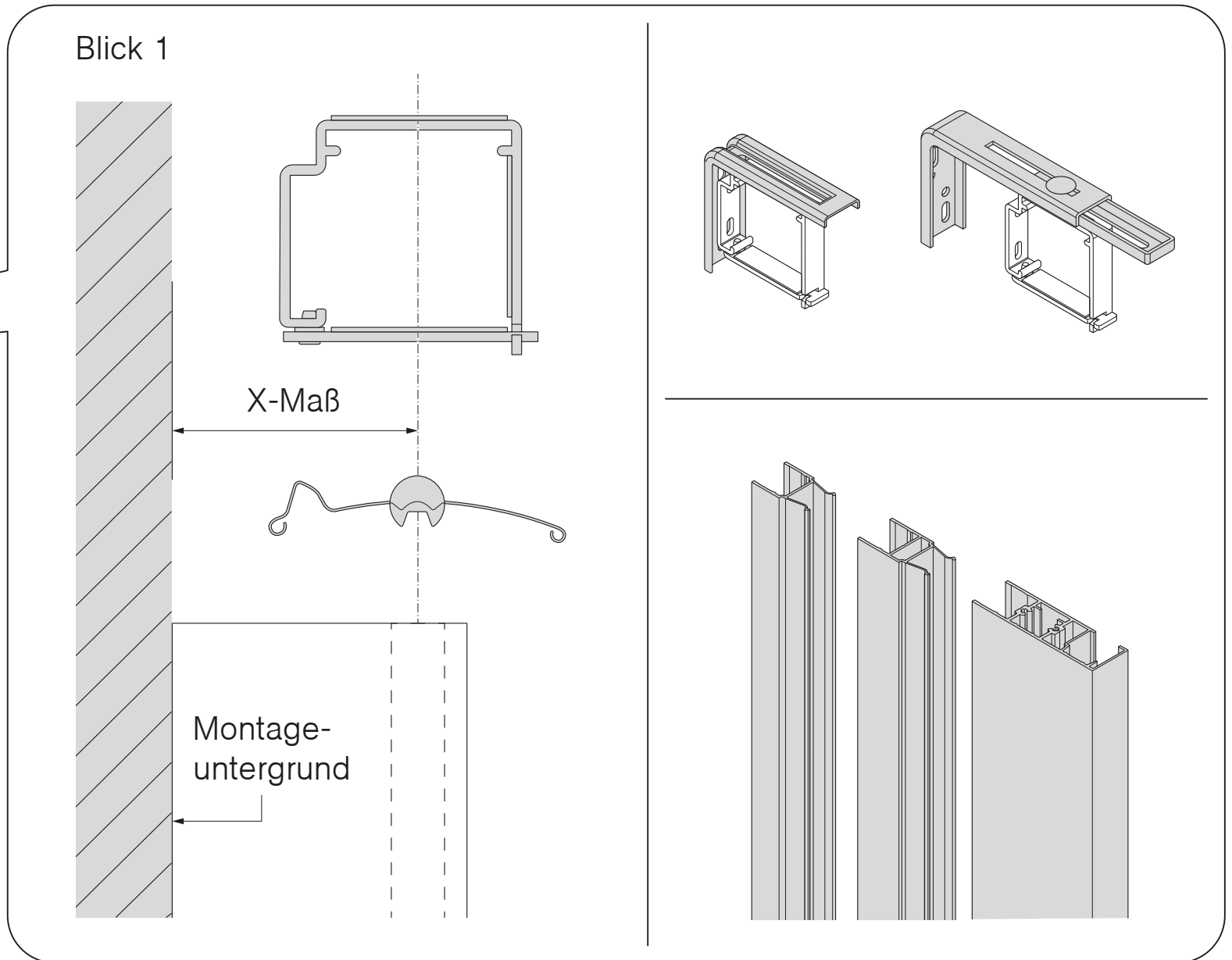
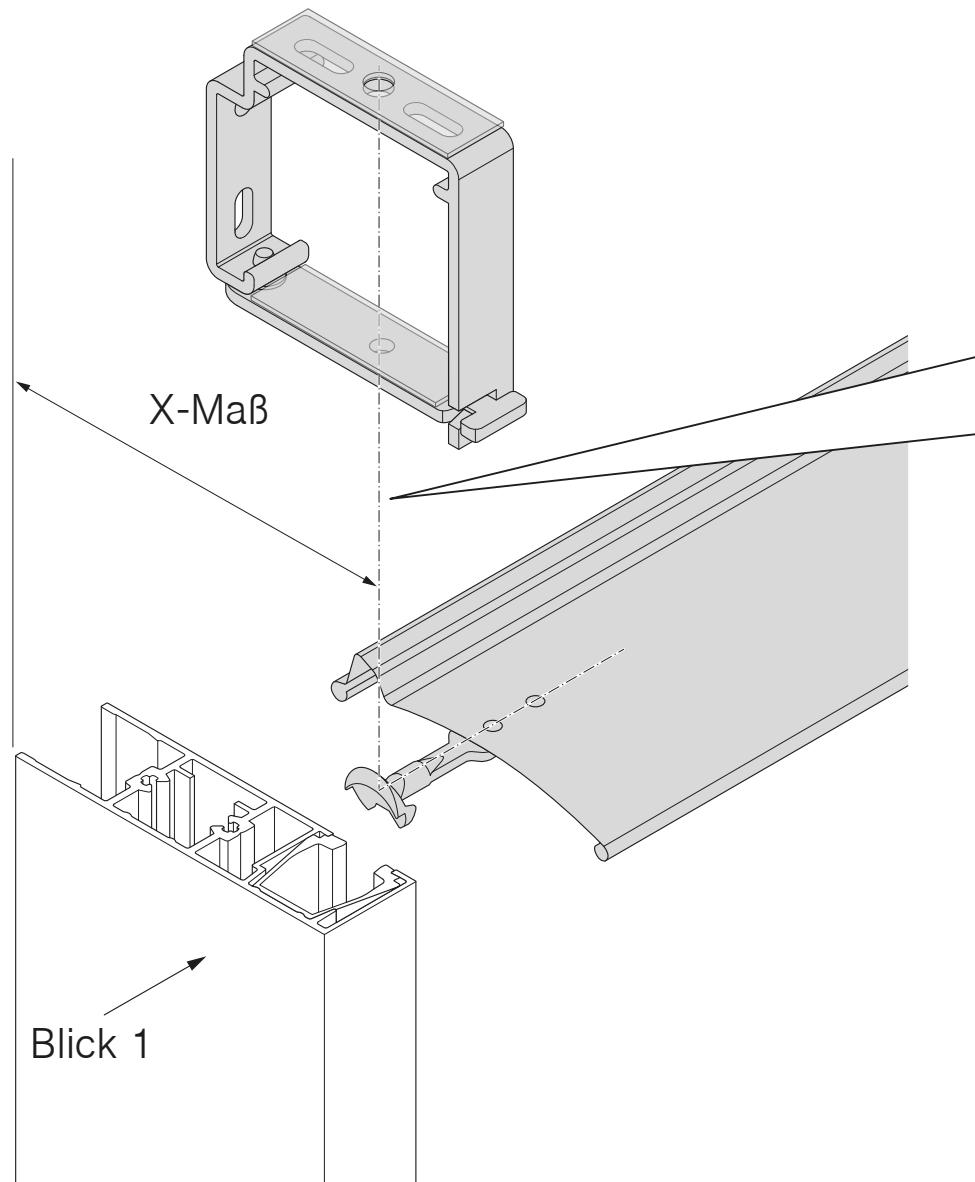

2

Oberschienträger/Blende anbringen

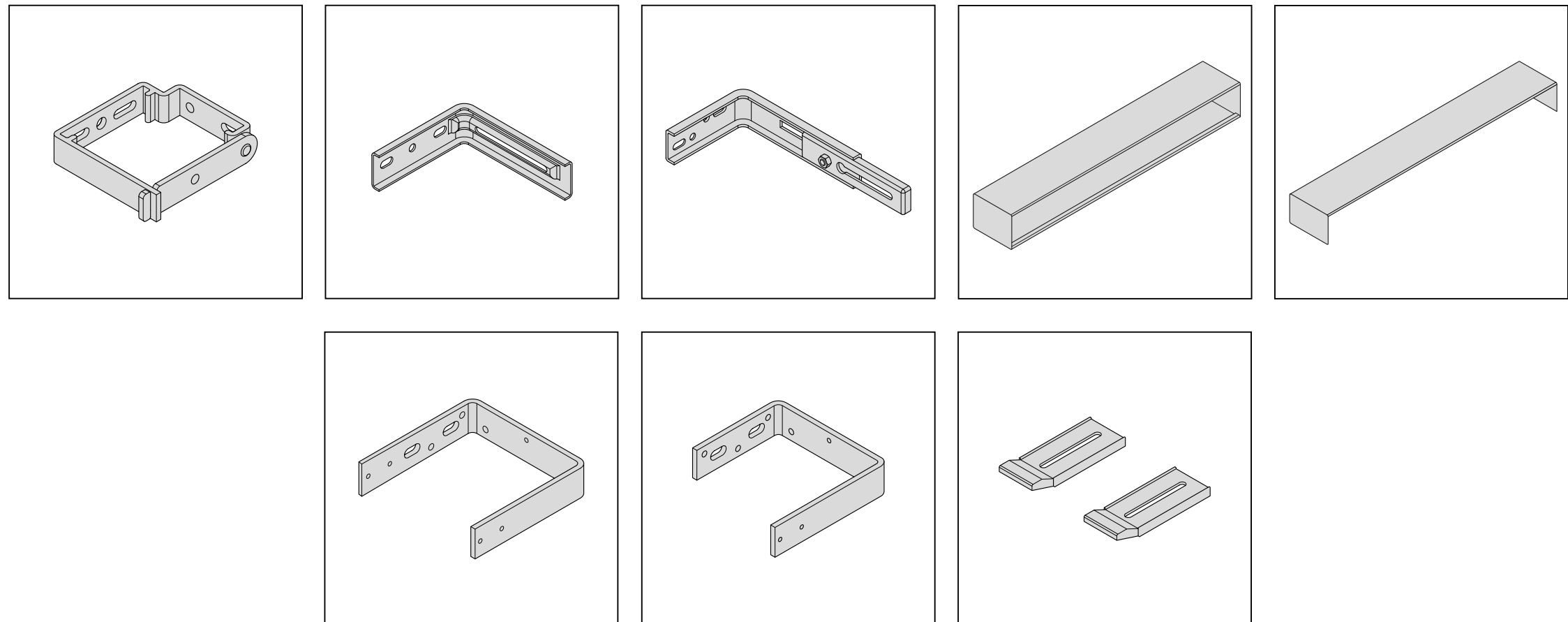

Raffstorepaket mit Führungsschiene mittig anzeichnen

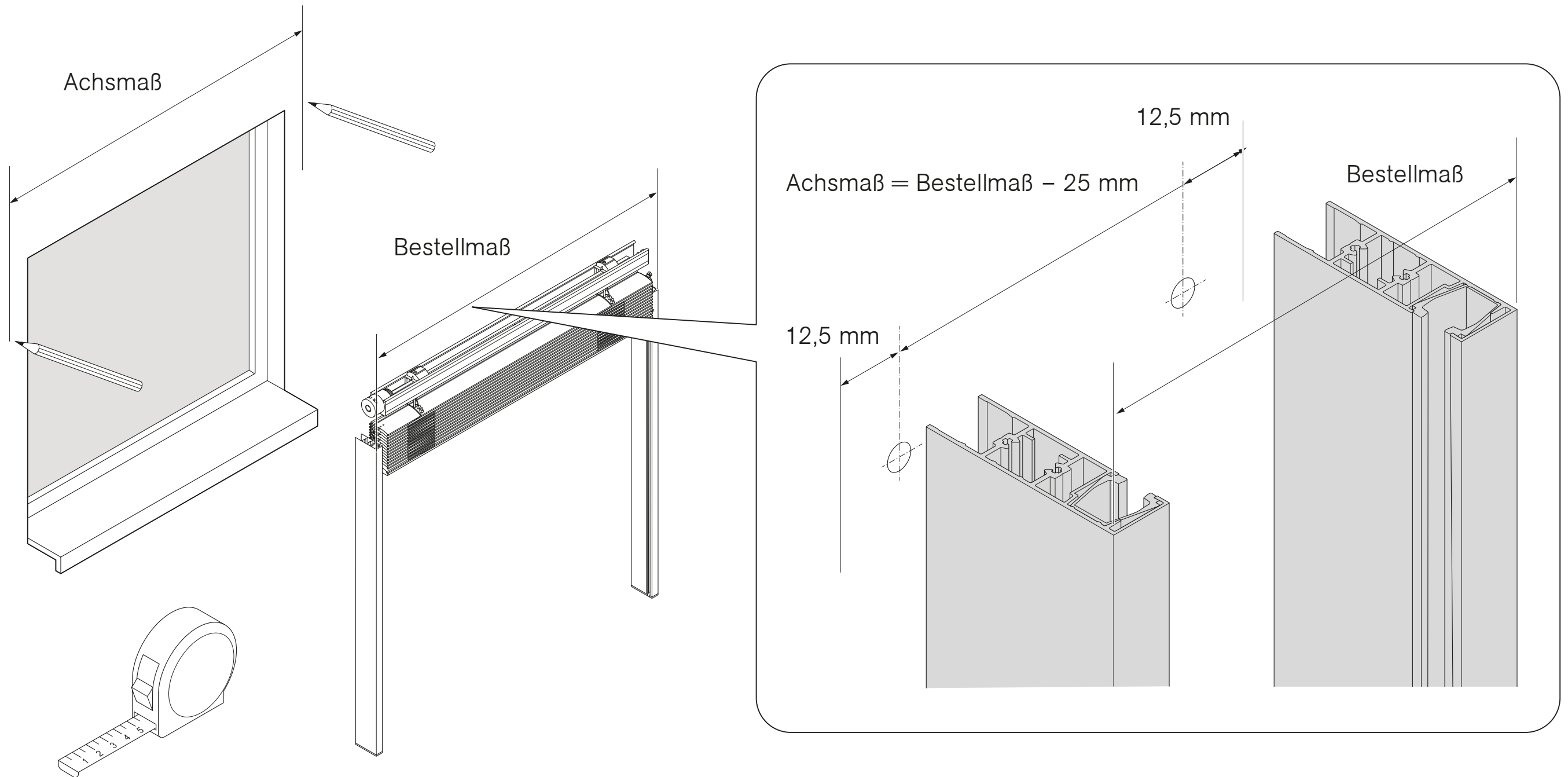

Bohrung für die Achse des Kurbelantriebs

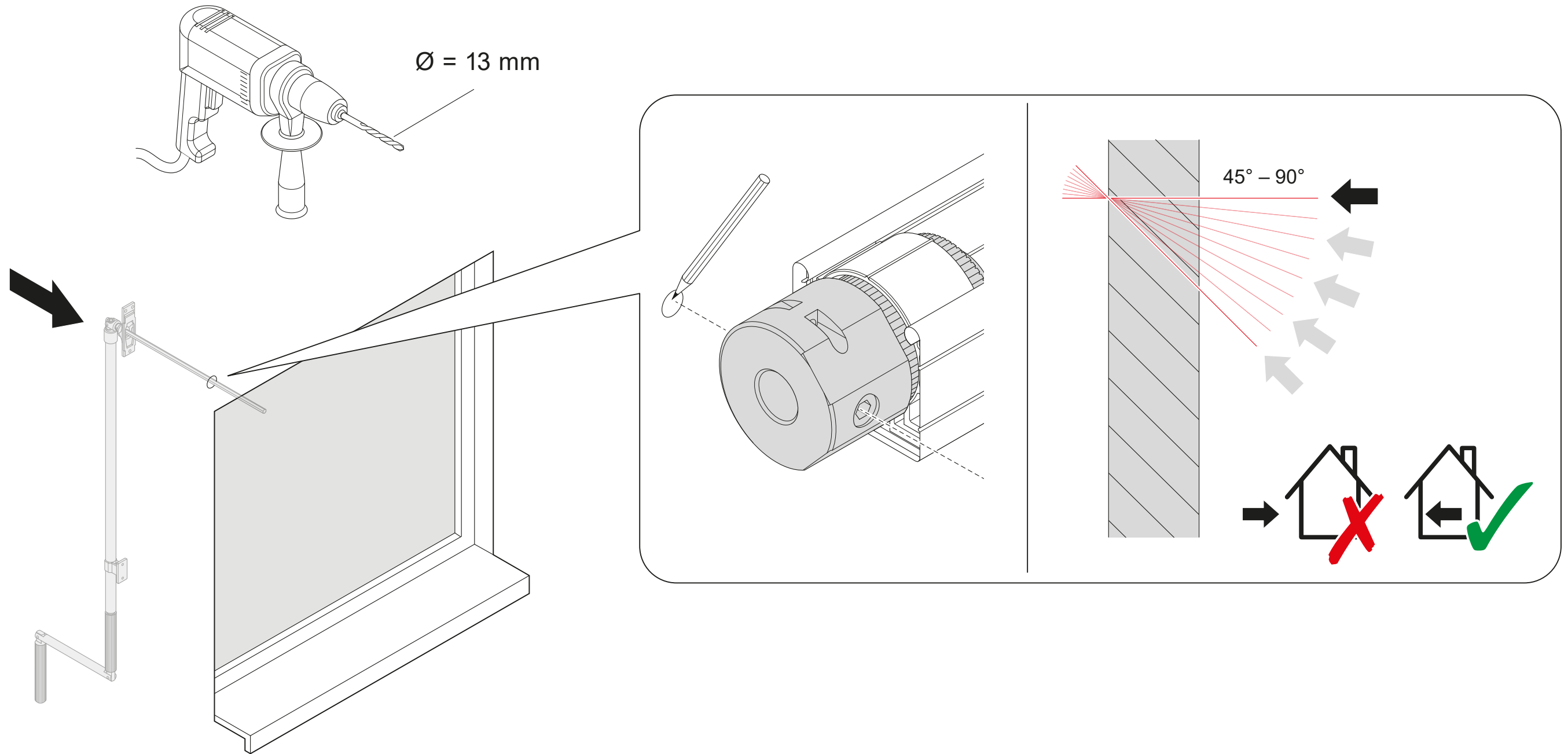

Generelle Position des Oberschienenträgers



X-Maß: siehe Seite 12
B: siehe Seite 10 ff.

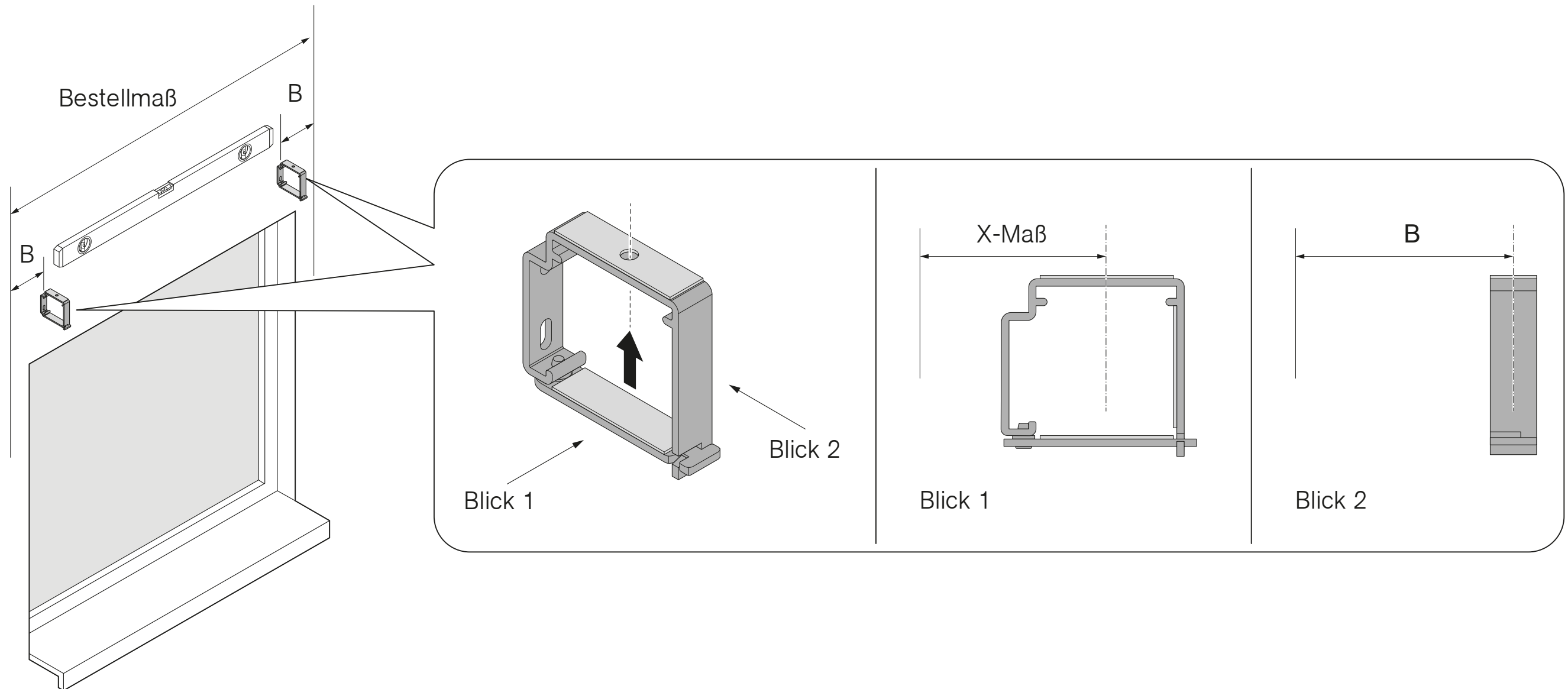

Generelle Position des Oberschienenträgers

43000413

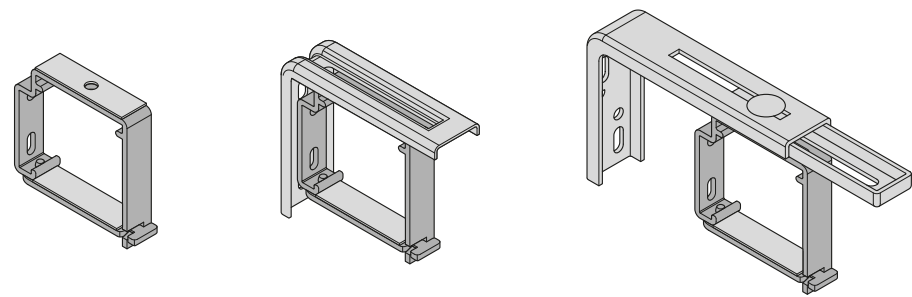
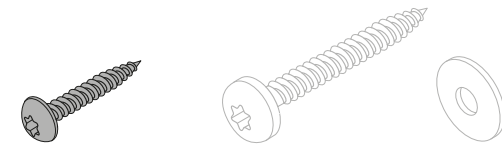

17

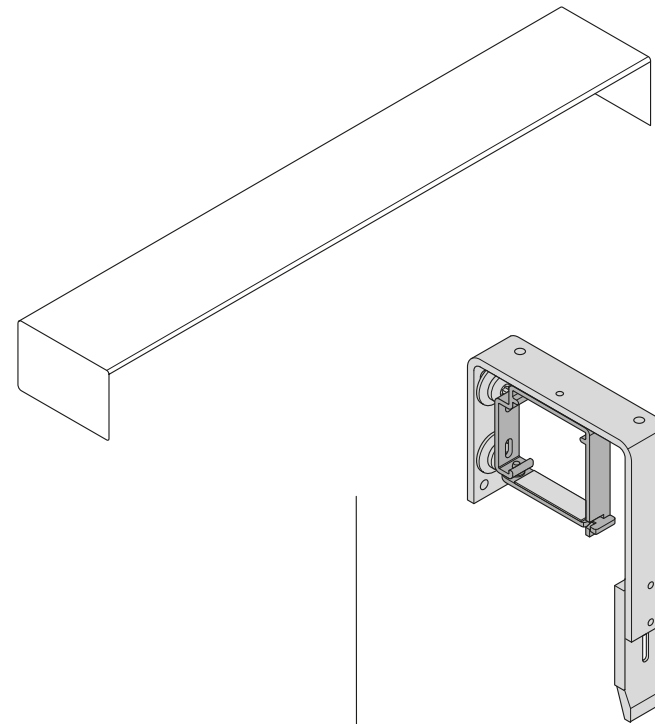

18

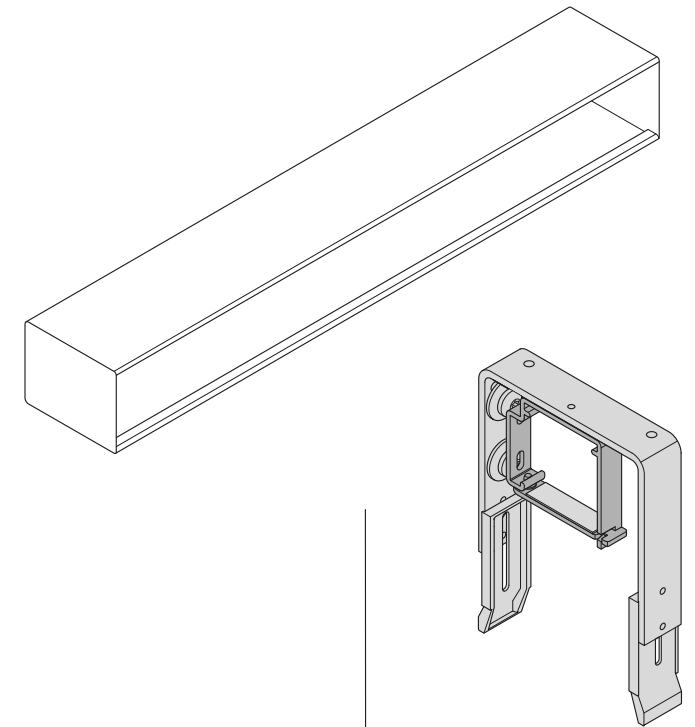

22

Oberschienenträger montieren

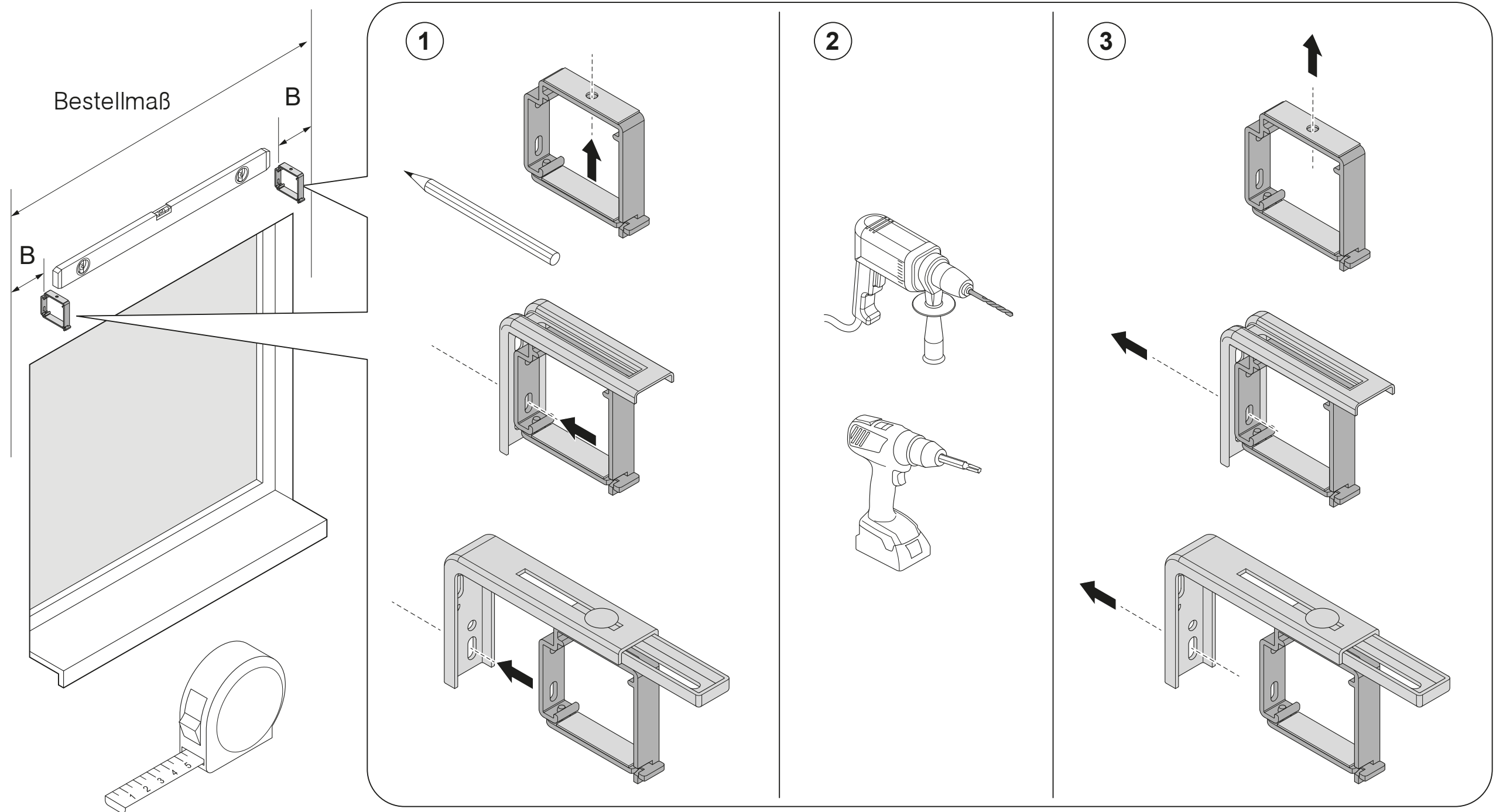

Versteifungsbügel für Winkelblende montieren

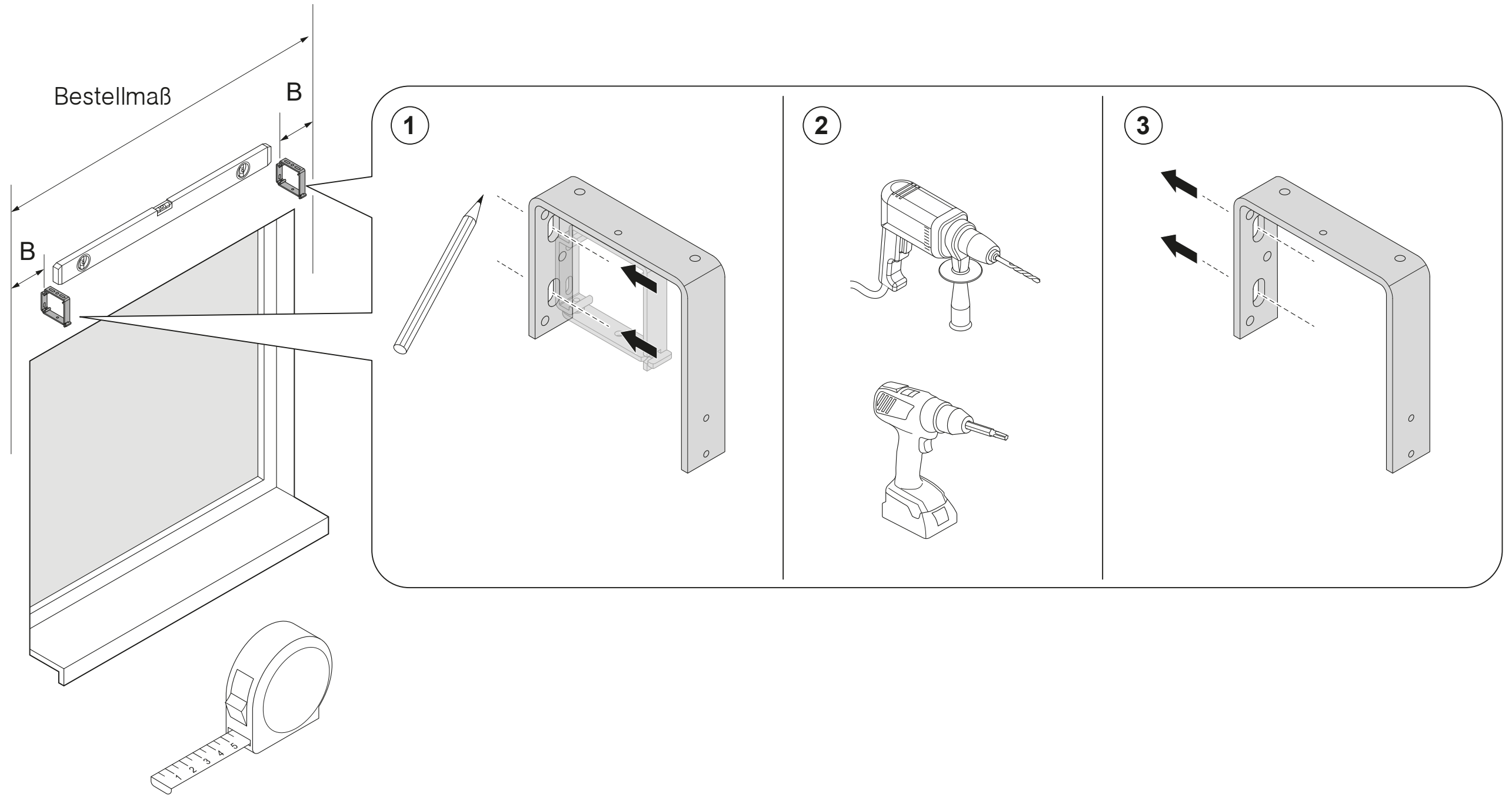

Winkelblende mittig zum Achsmaß am Versteifungsbügel befestigen



Befestigungsmaterial nicht im Lieferumfang enthalten.

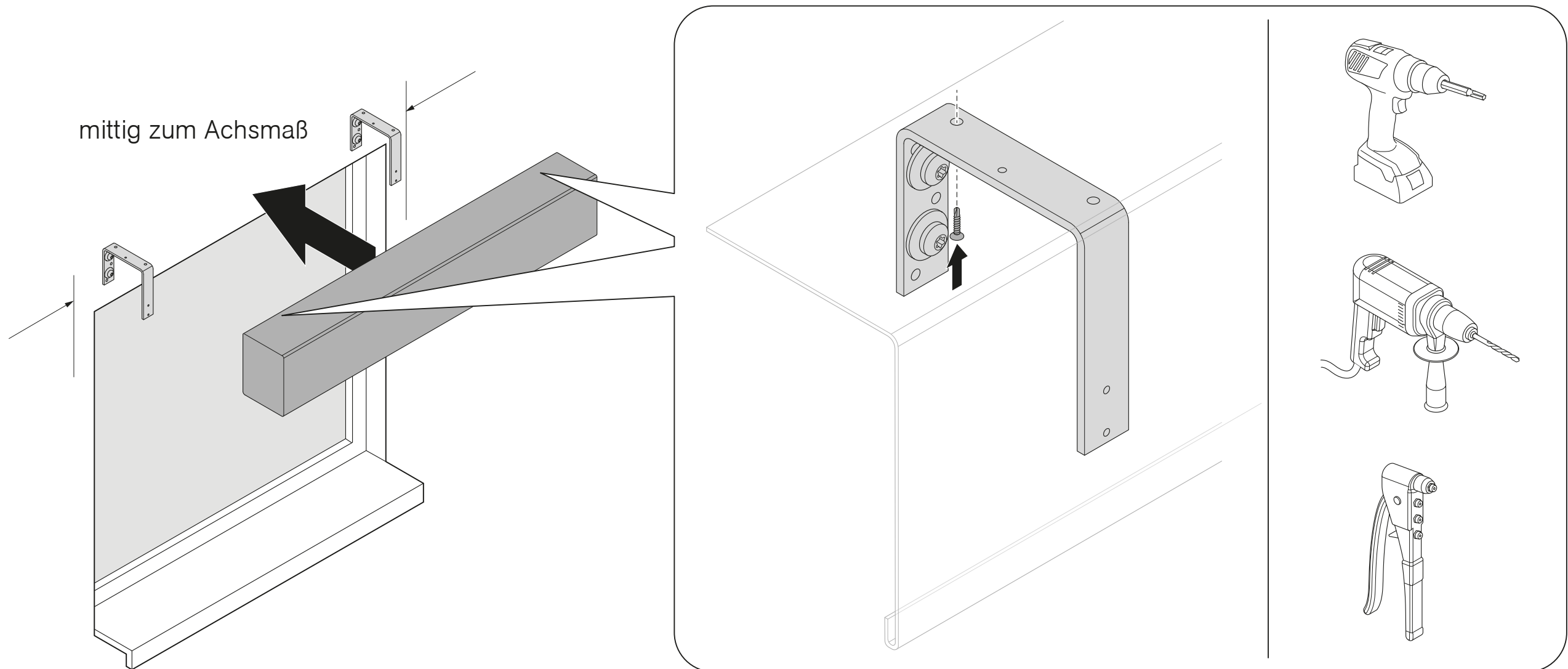

Versteifungsbügel befestigen

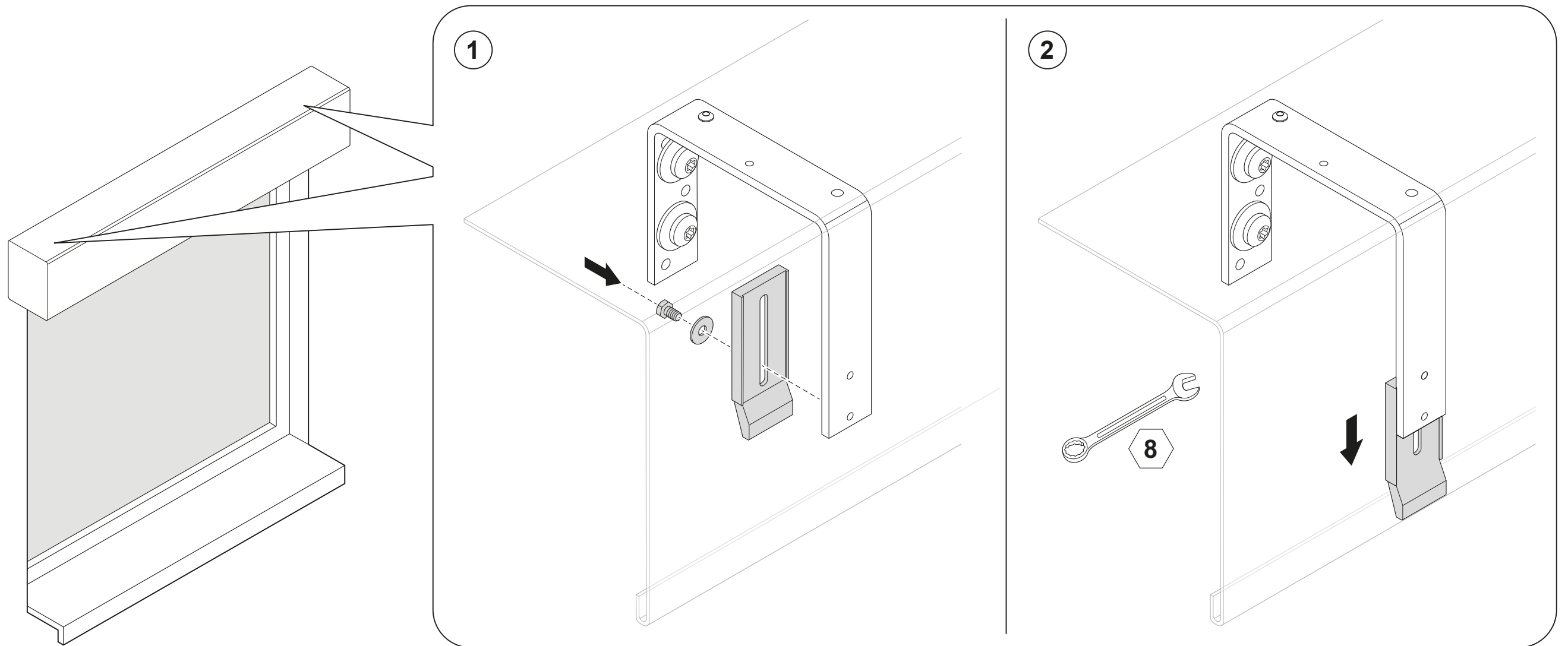

Oberschienenenträger an Versteifungsbügel schrauben

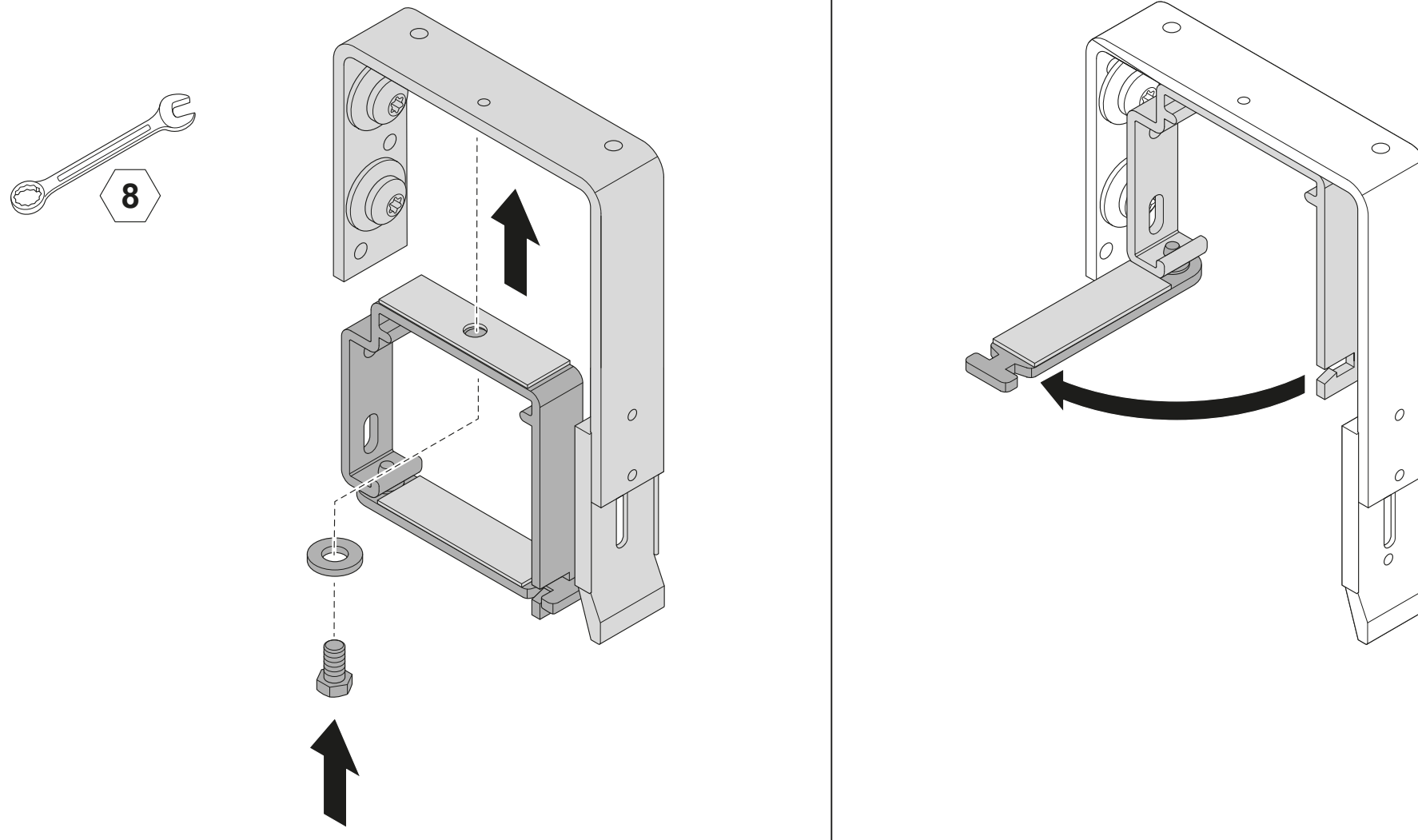

Versteifungsbügel und Bohrung für Kurbel auf Blende anzeichnen



B: siehe Seite 10

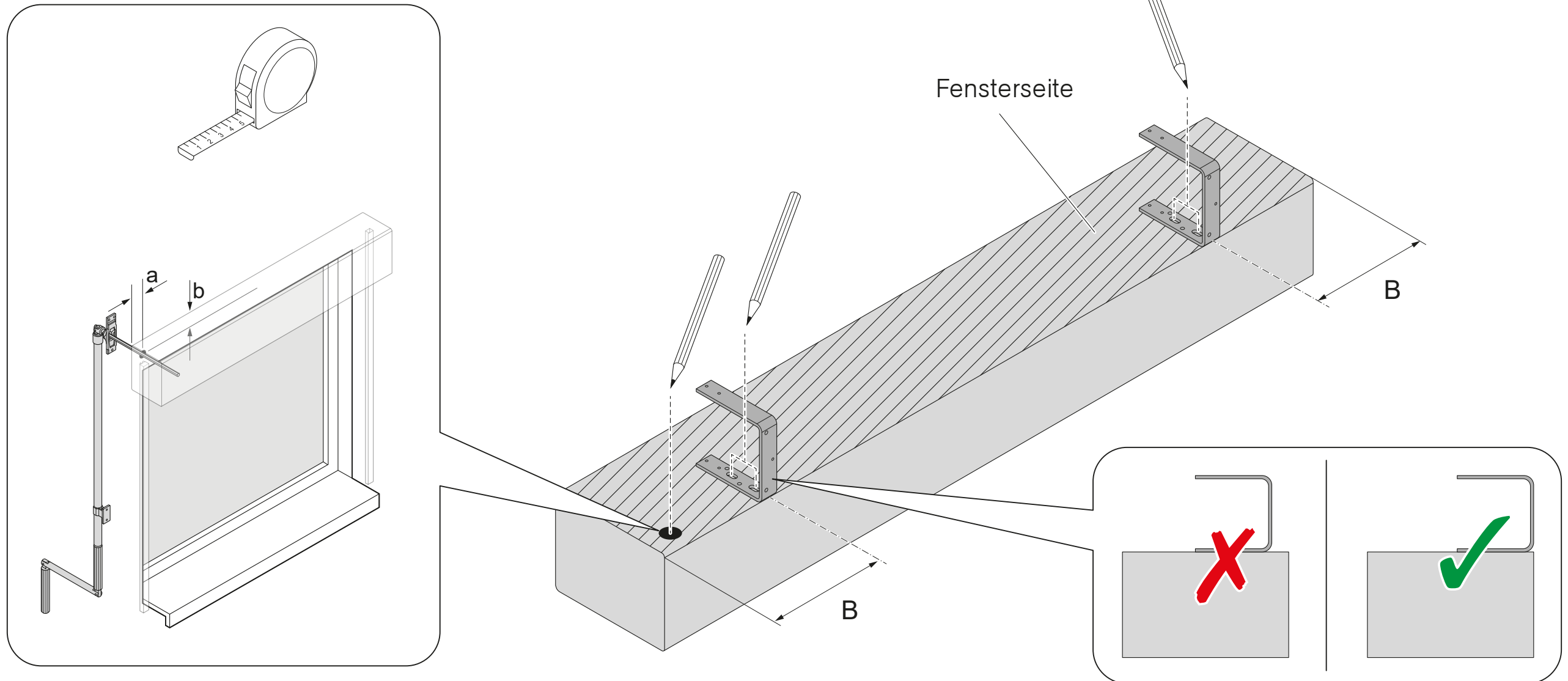

Bohrungen für Versteifungsbügel und Kurbel

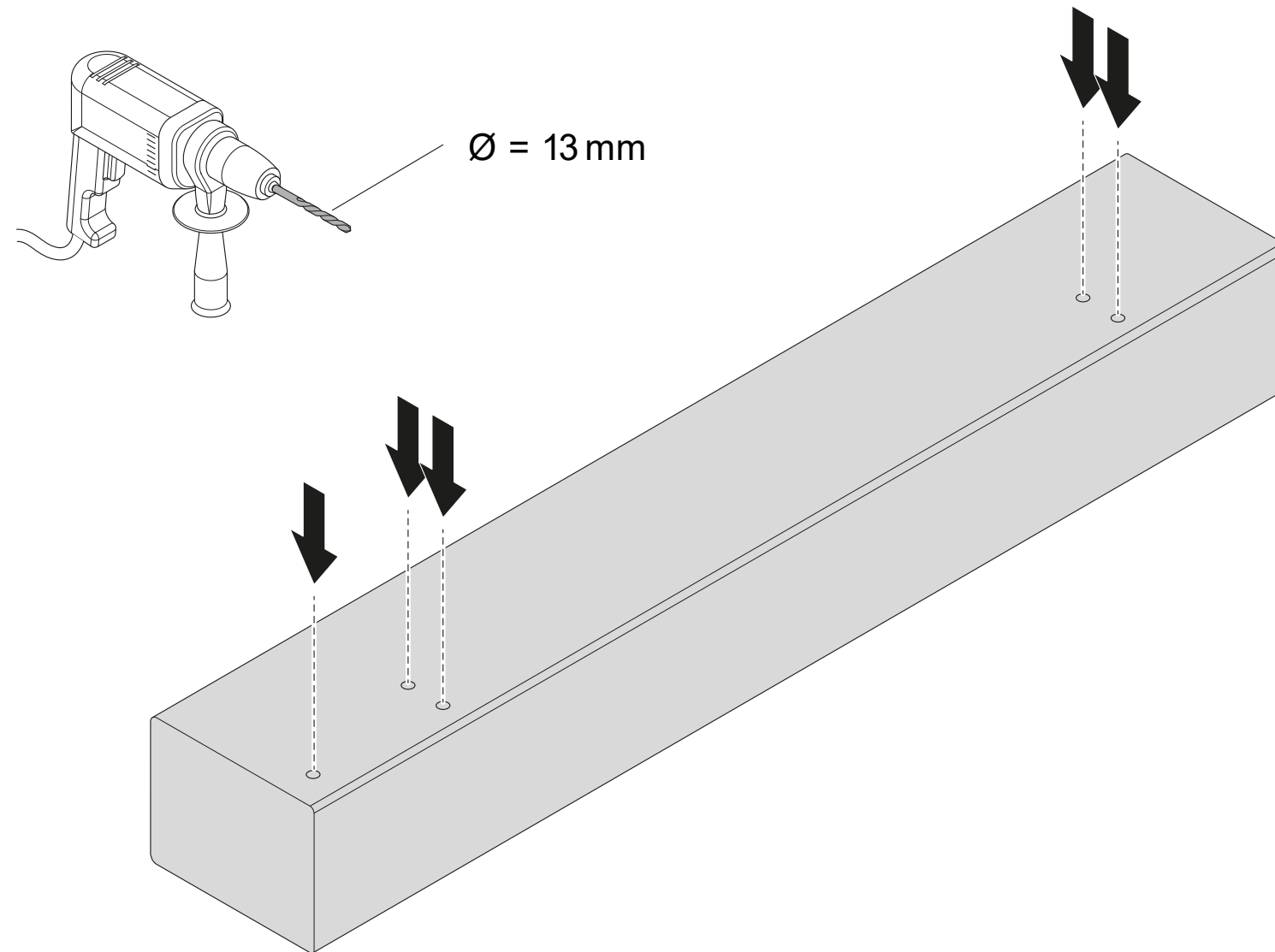

Versteifungsbügel anbringen

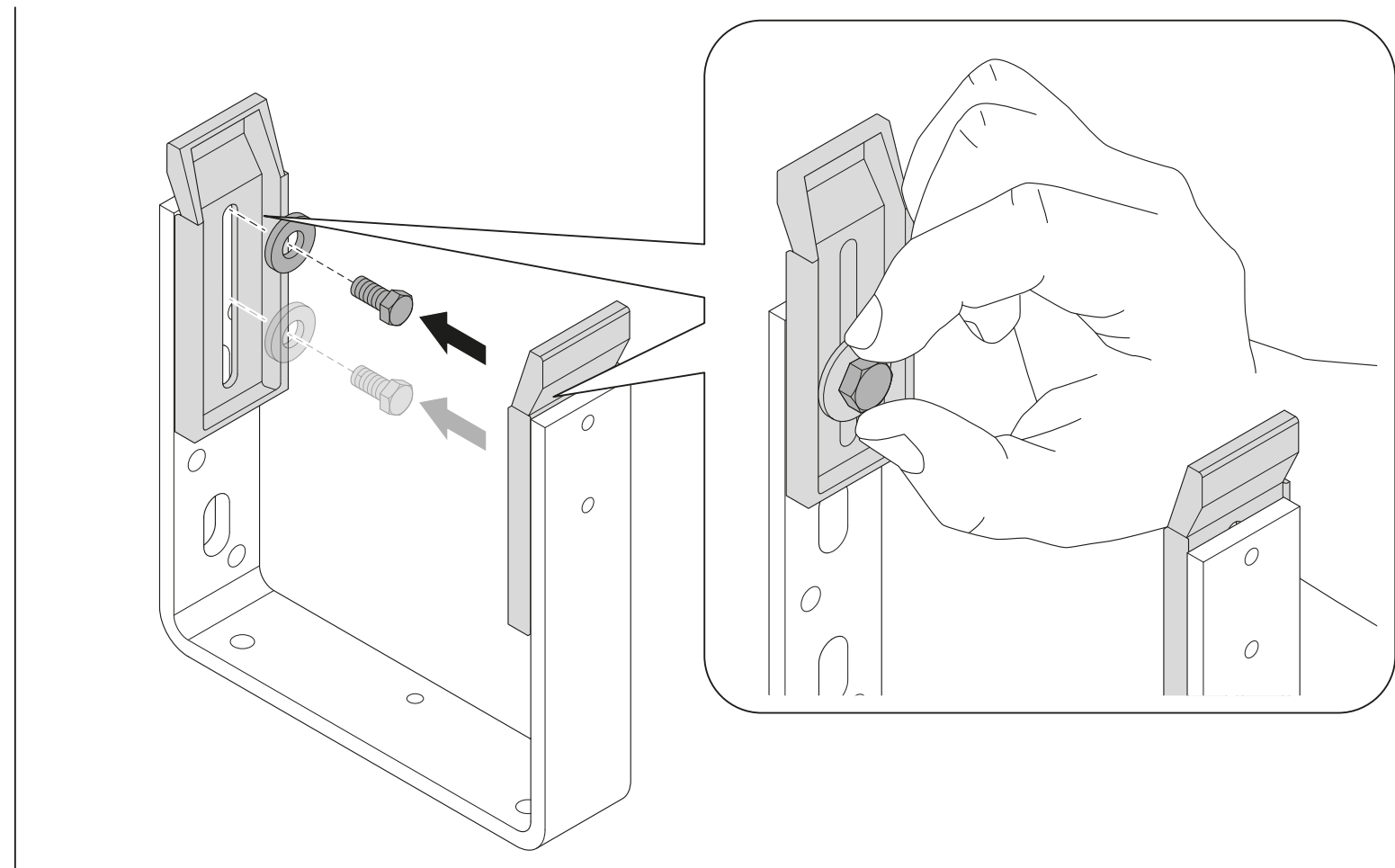
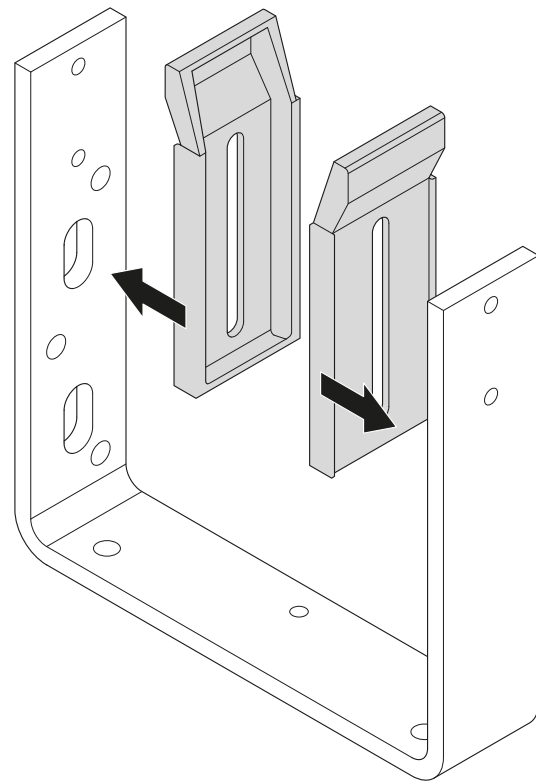

Versteifungsbügel anbringen

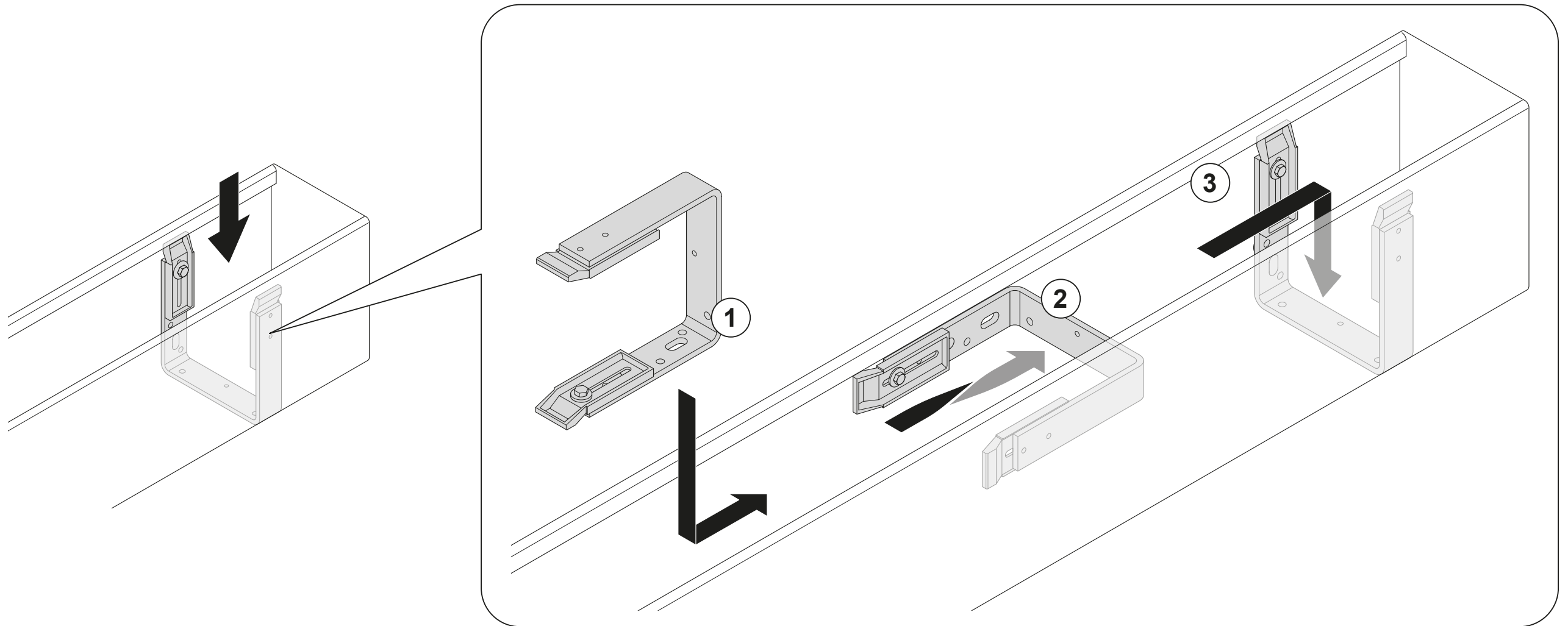

Versteifungsbügel anbringen

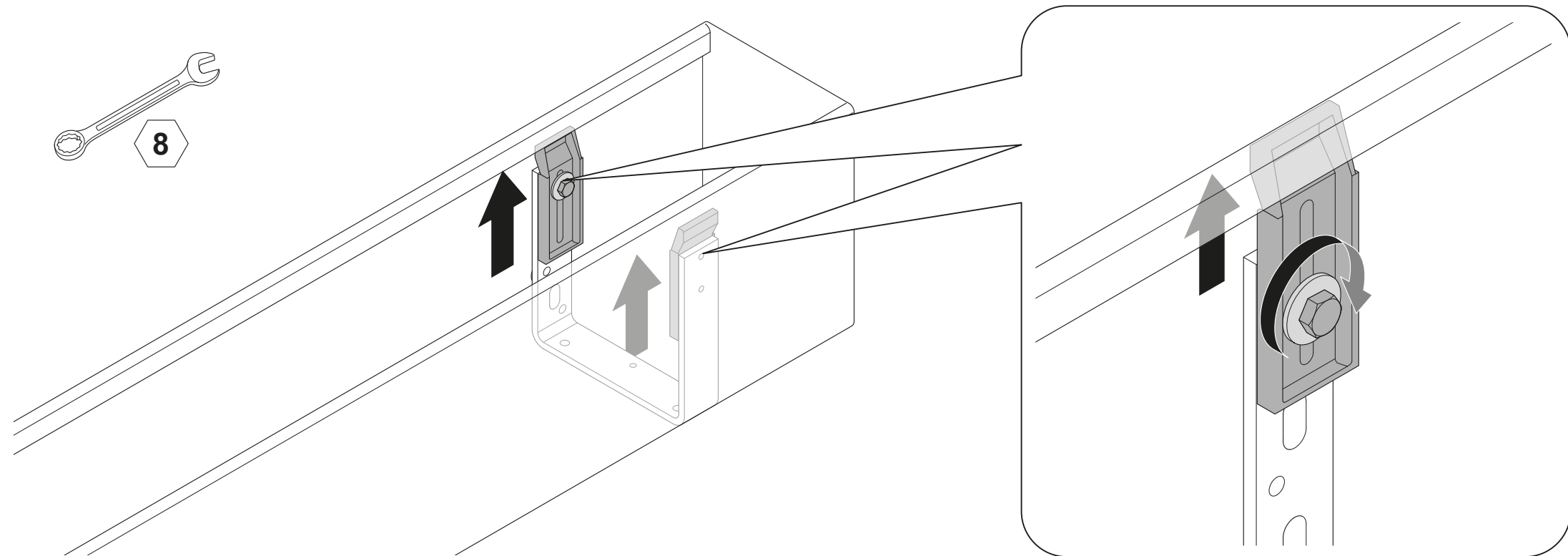

Blende auf Montageuntergrund mittig zum Achsmaß befestigen

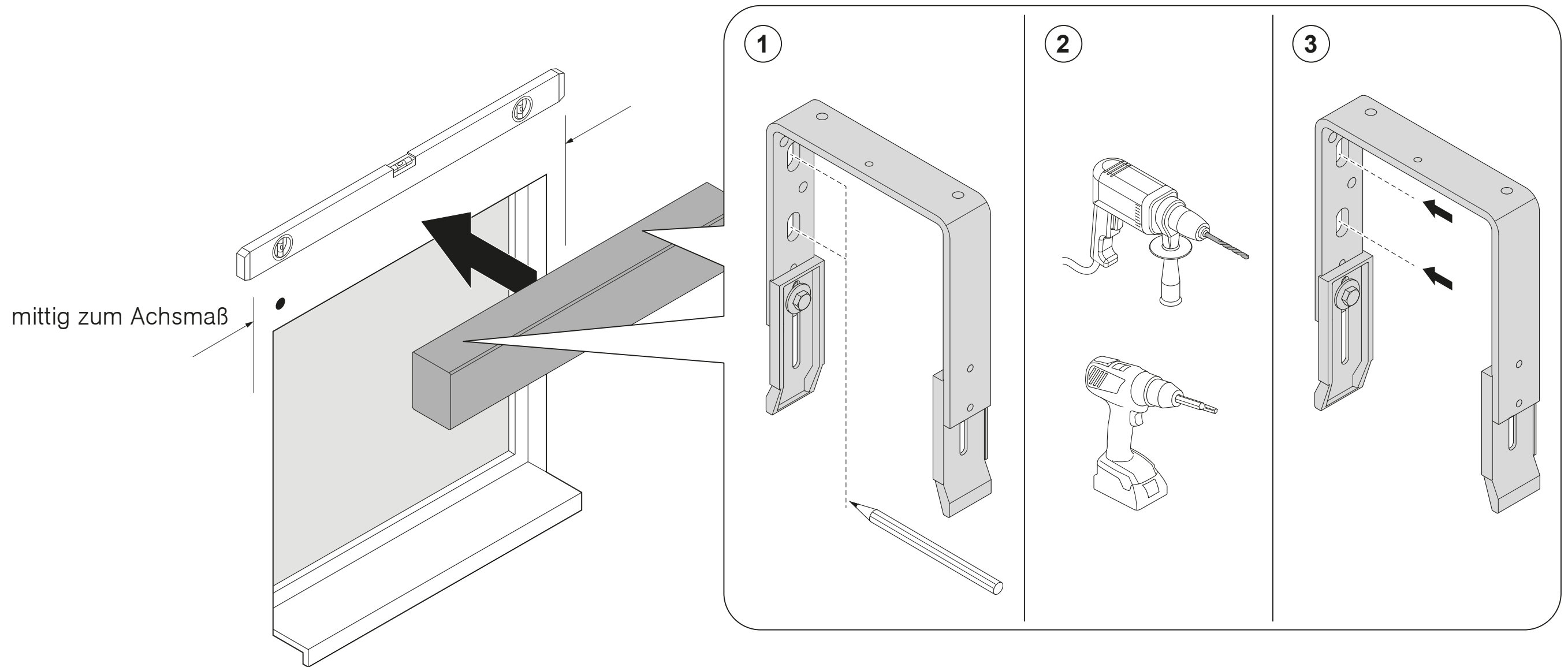

Oberschienenenträger an Blende/Versteifungsbügel schrauben

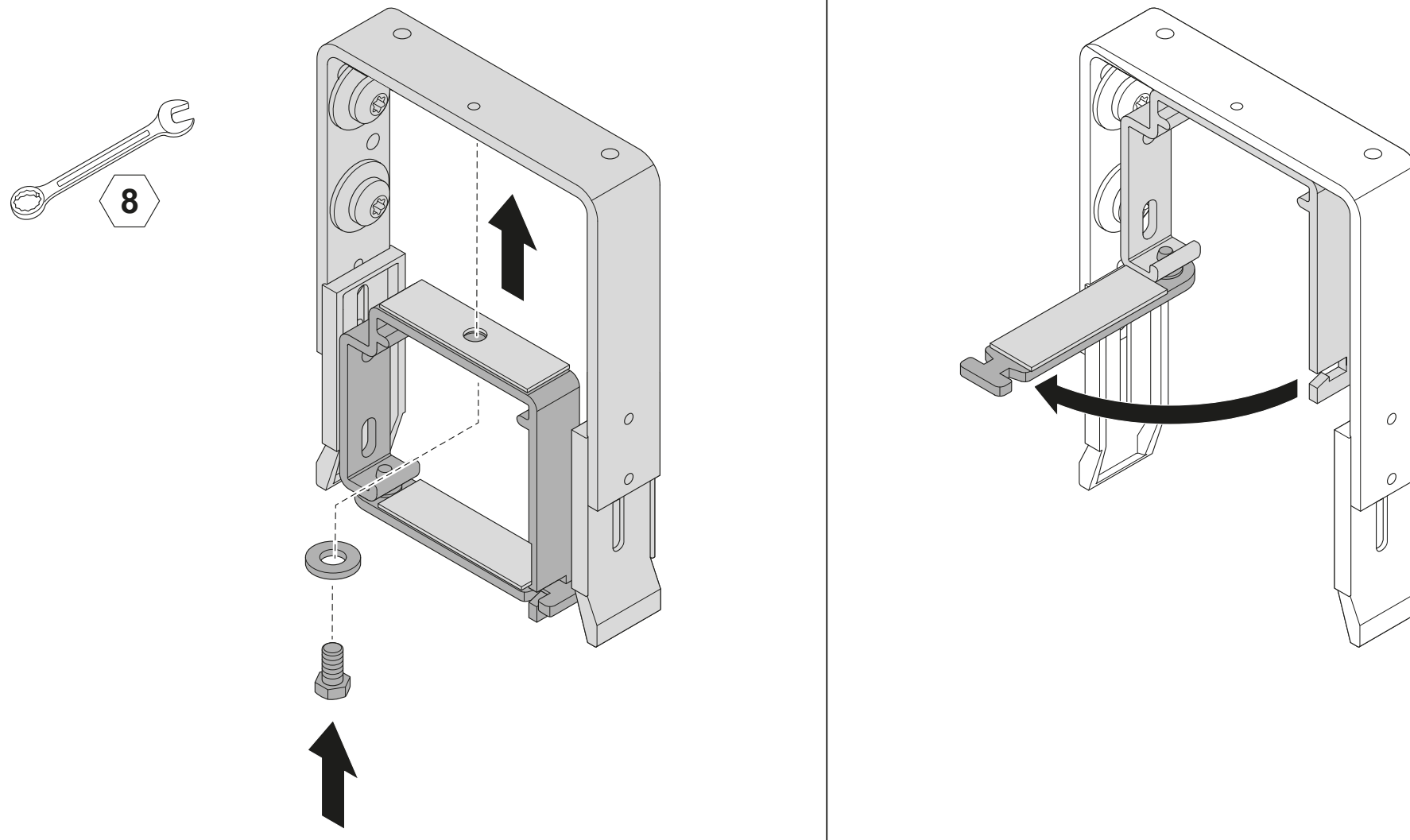

3

Raffstorepaket einhängen

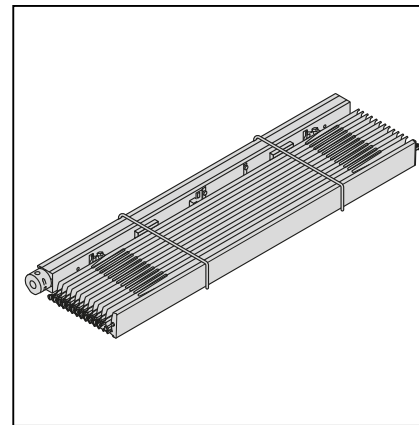

Oberschiene und Raffstore vorbereiten

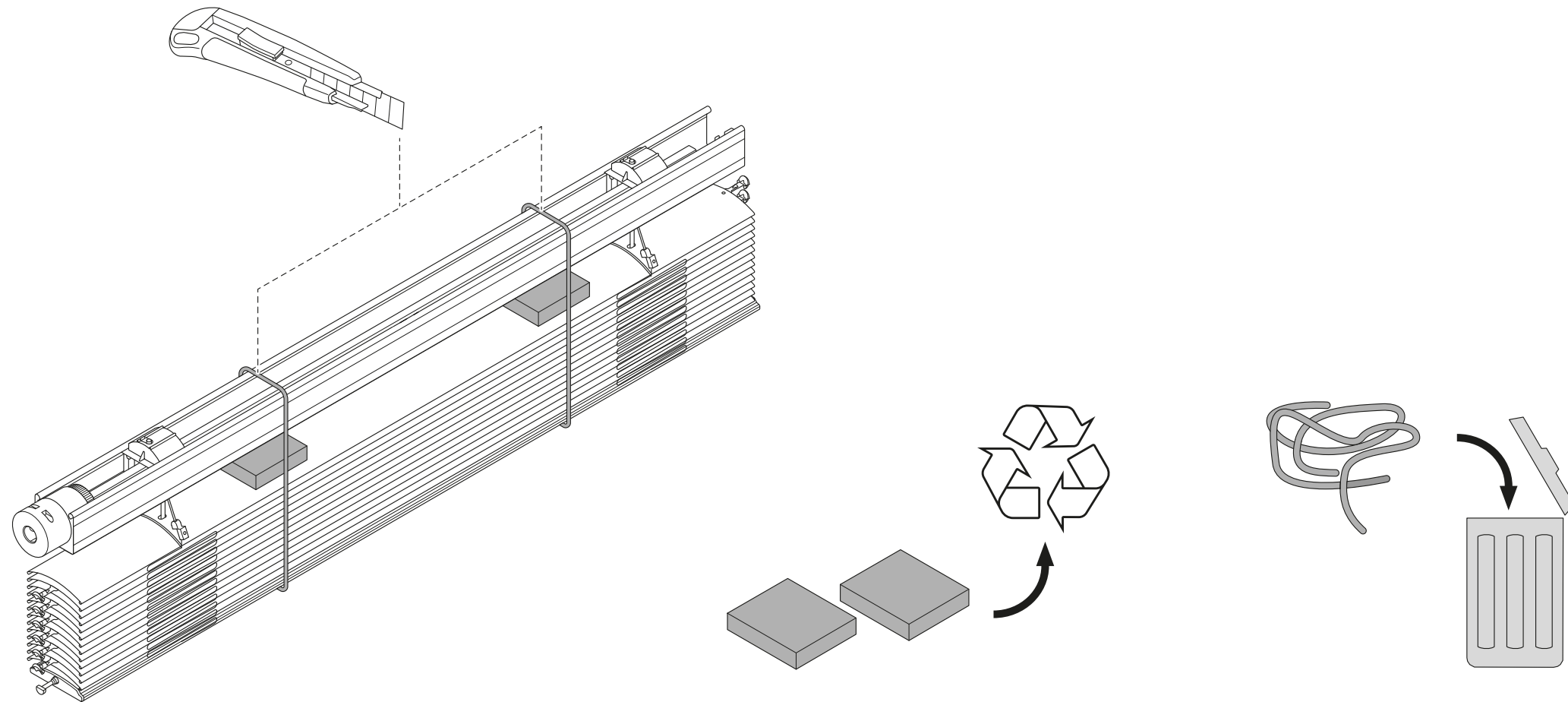

Oberschiene und Raffstore vorbereiten



Fenster- bzw. Wandseite beachten!

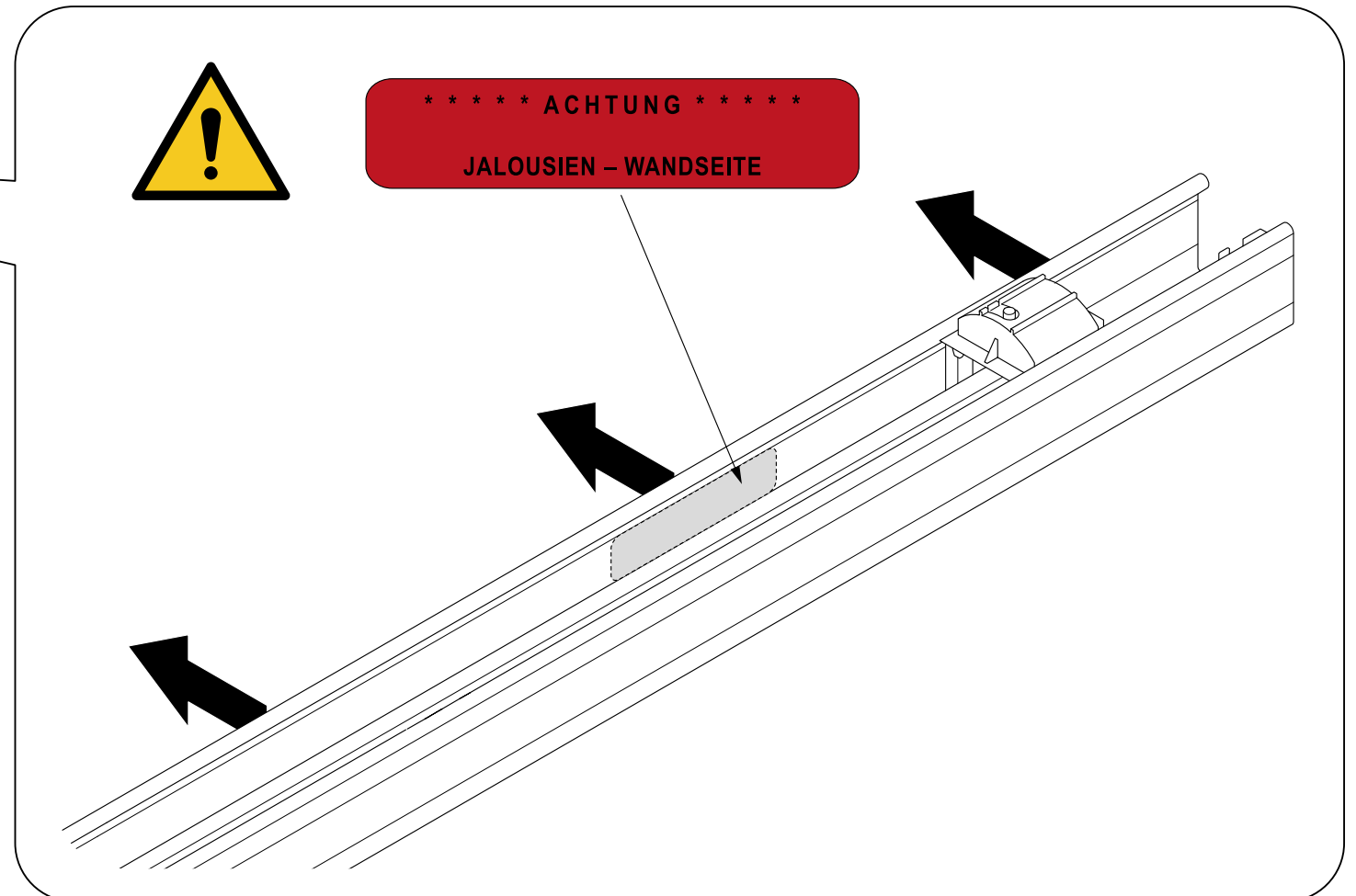
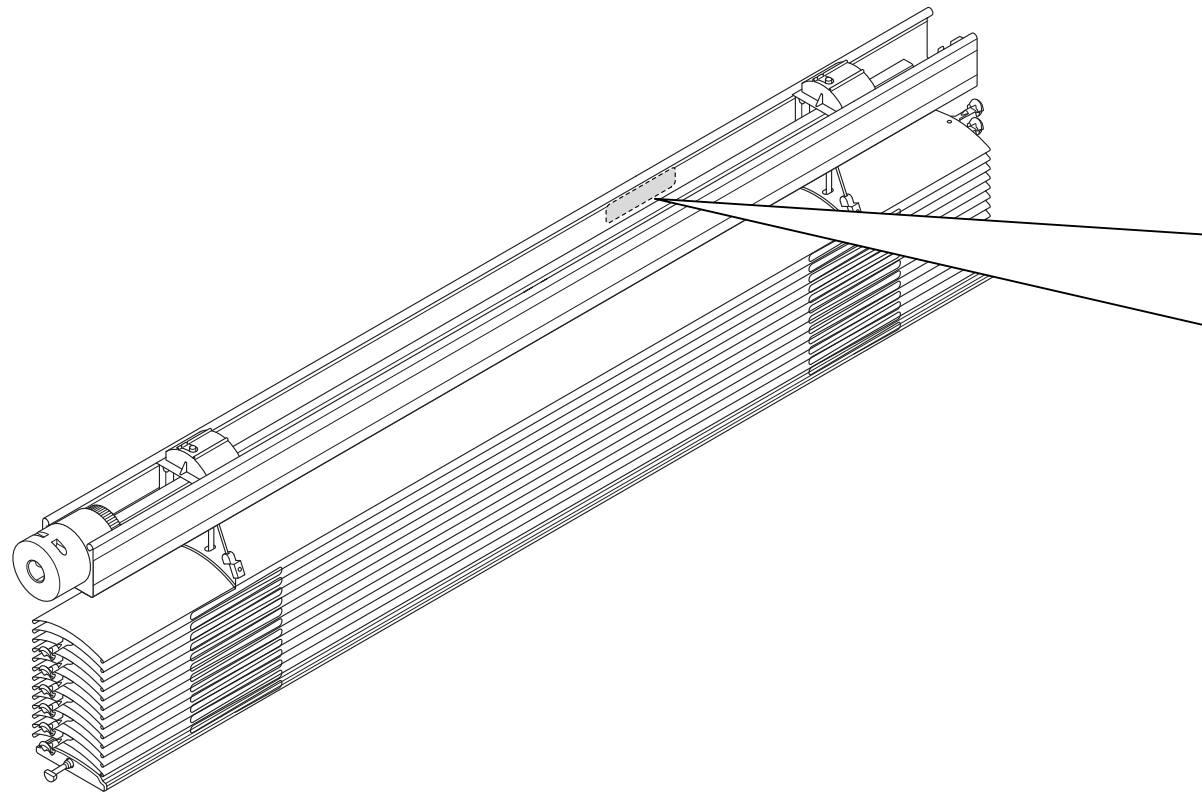

Oberschiene mit Raffstore in Oberschienenenträger mittig einhängen

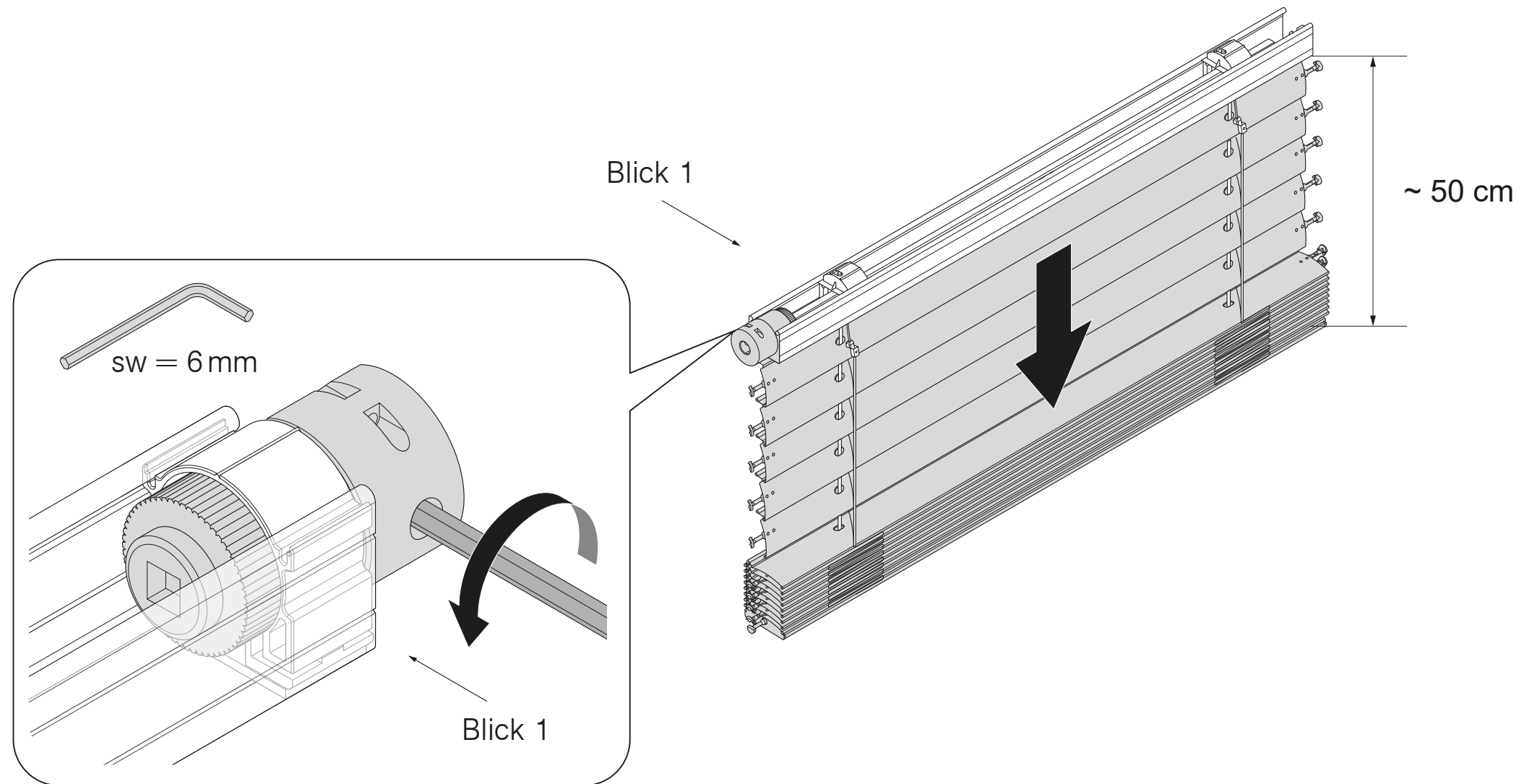

Oberschiene mit Raffstore in Oberschienenenträger mittig einhängen

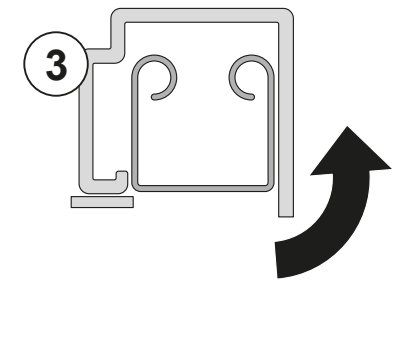
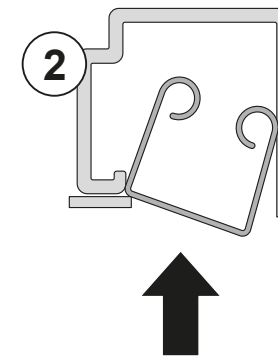
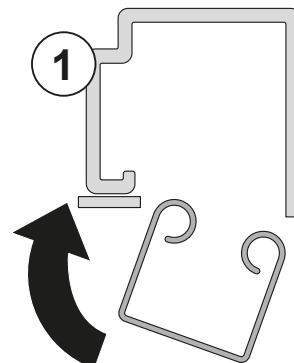
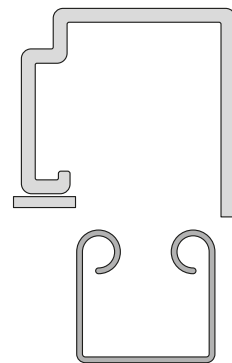
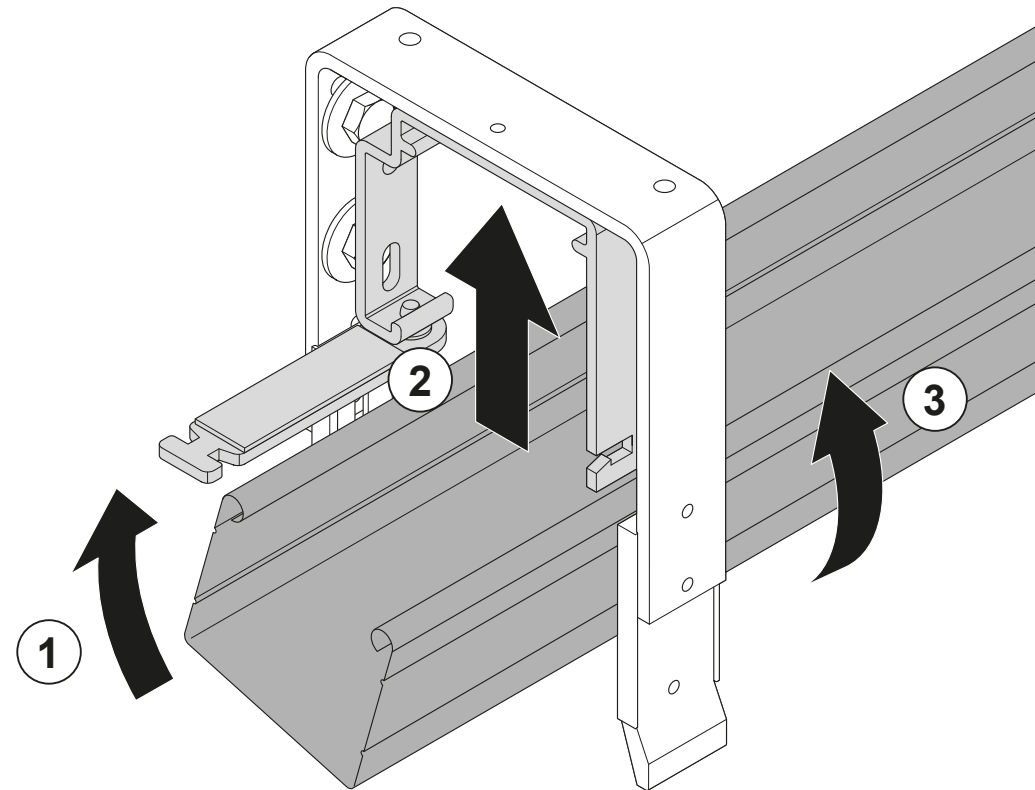
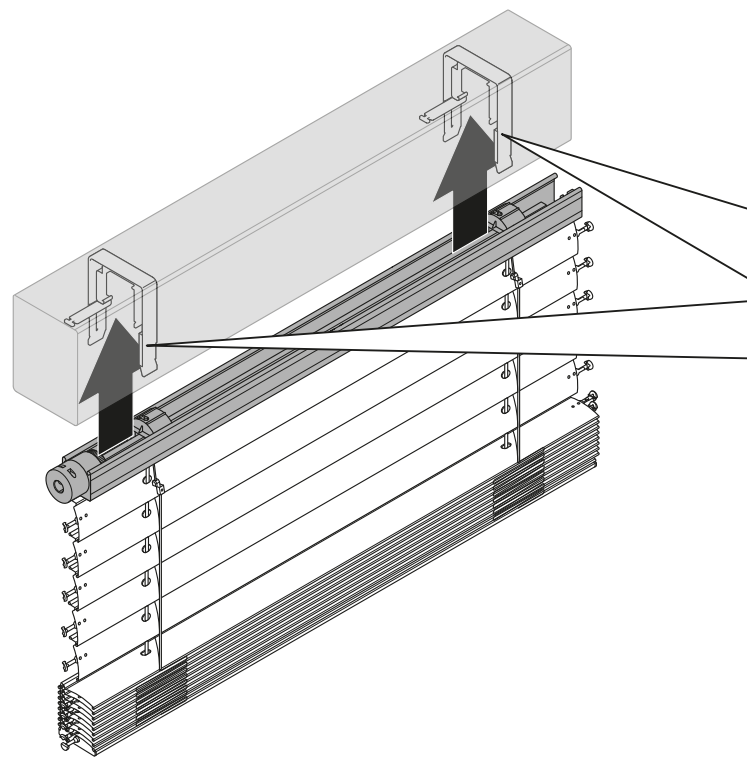

Oberschiene mit Raffstore in Oberschienenenträger mittig einhängen

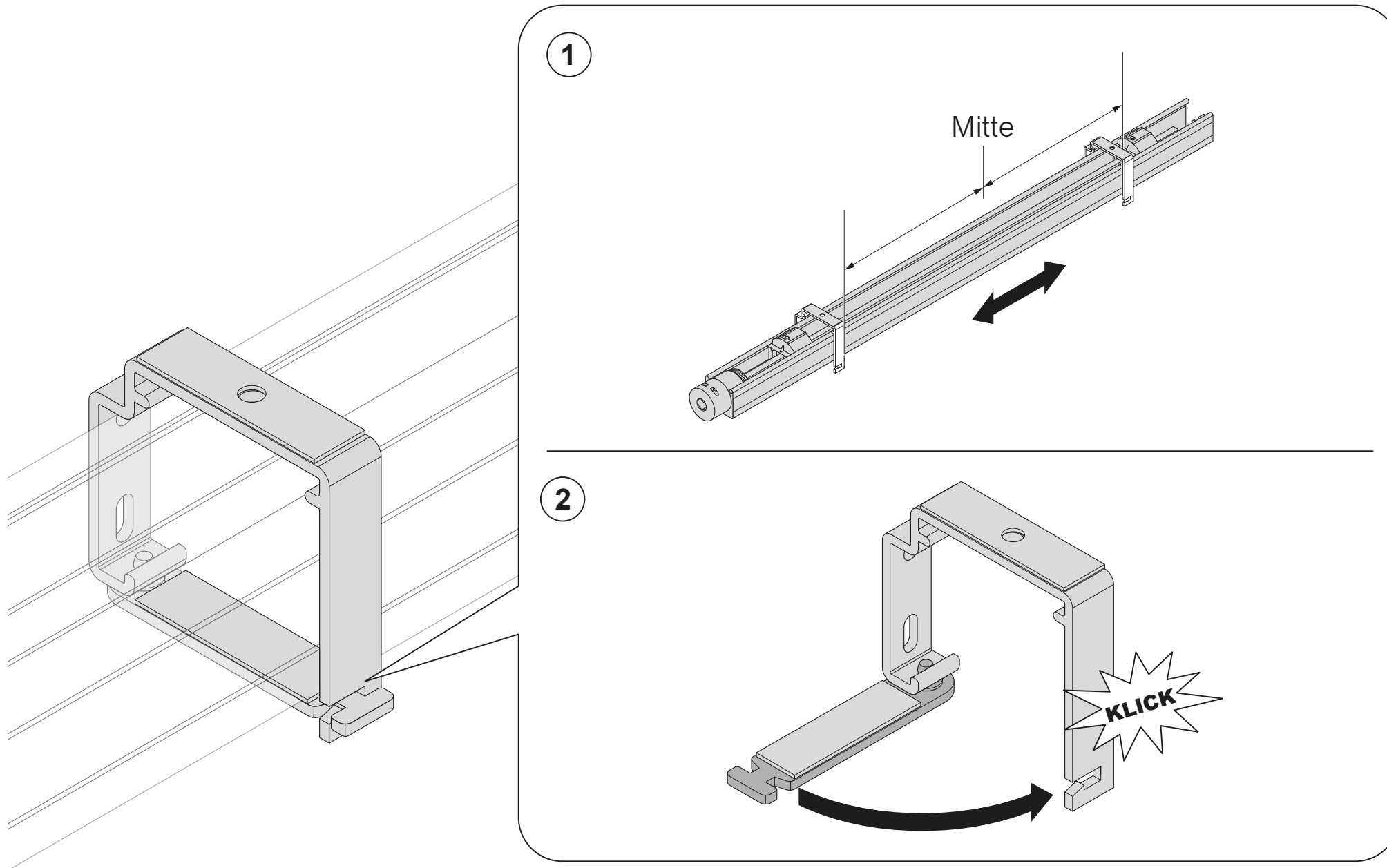

Optional: Behangkopplung

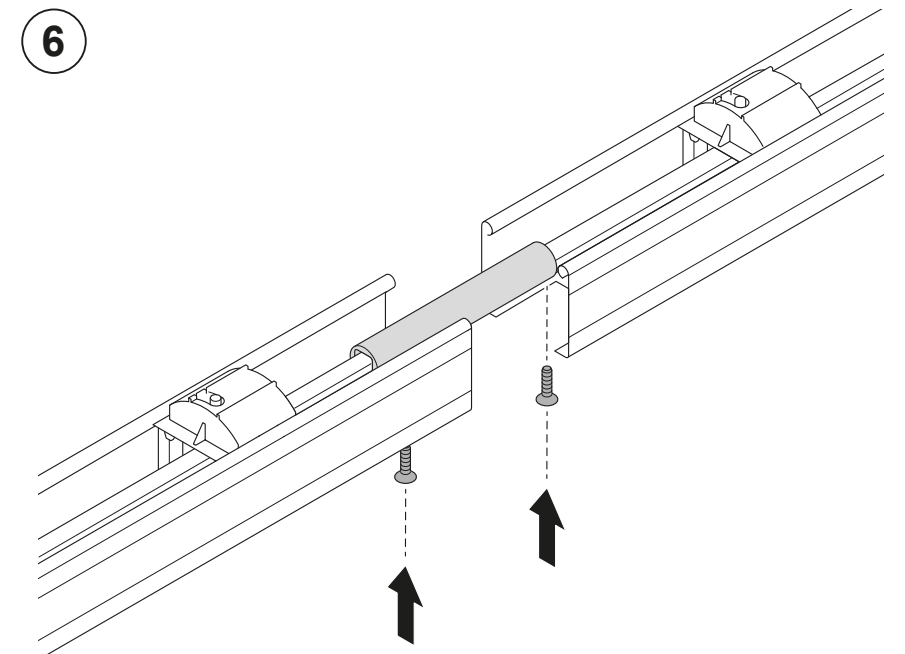
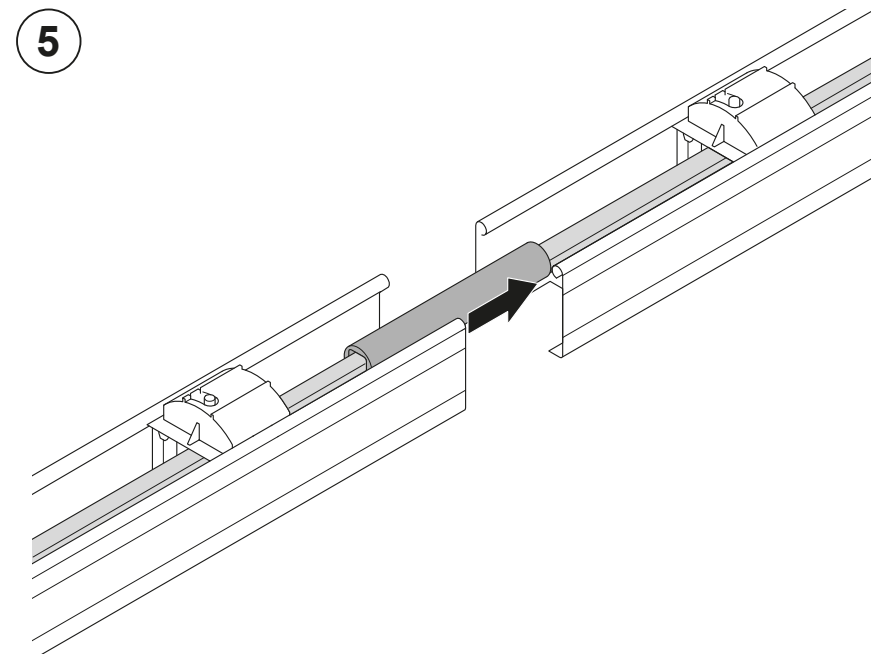
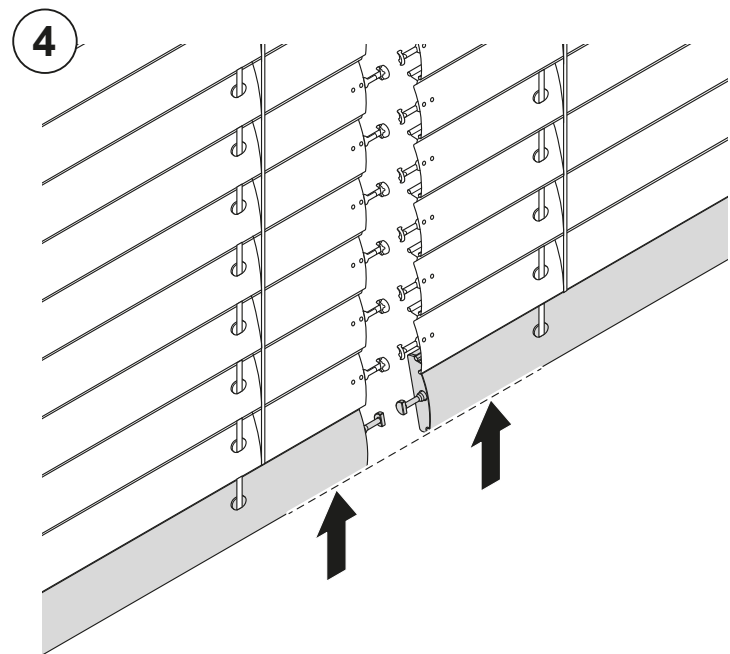
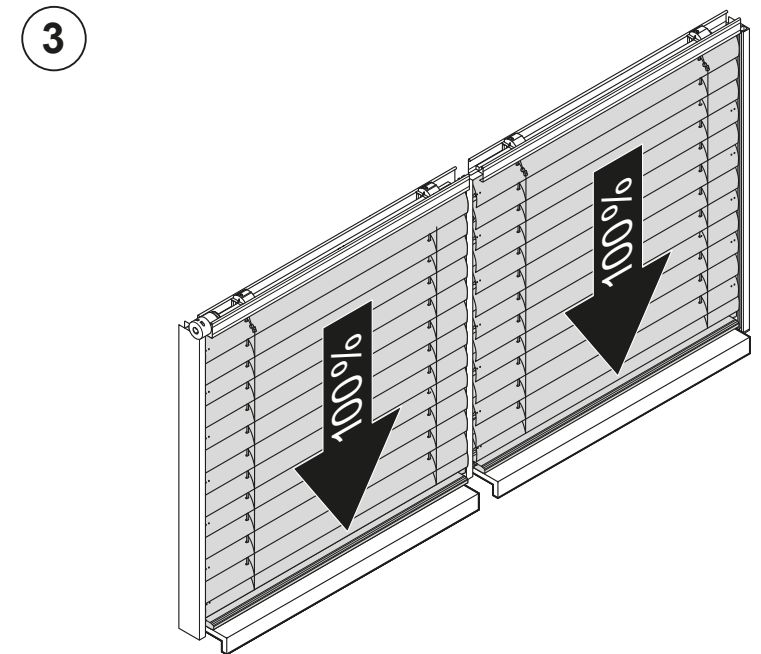
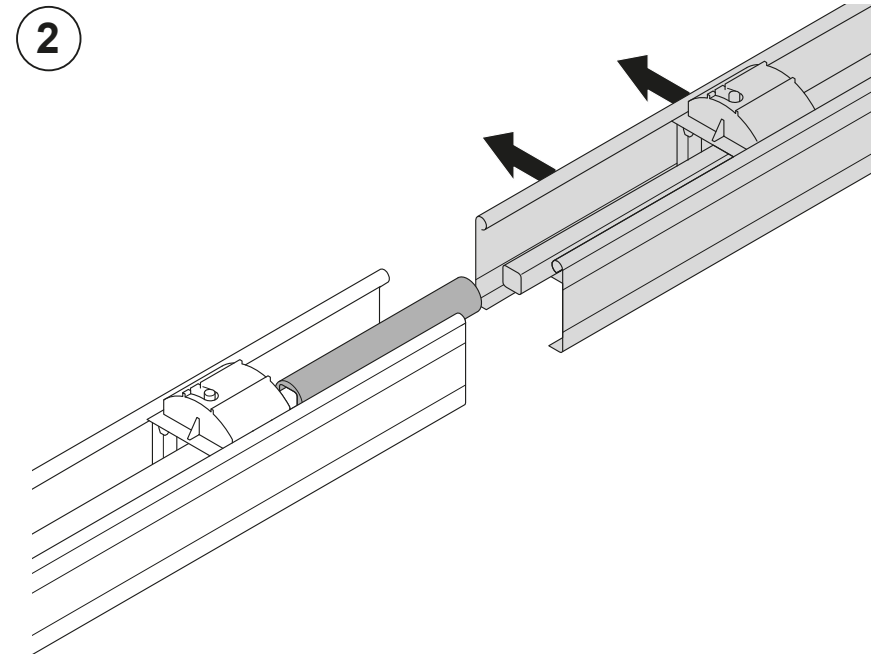
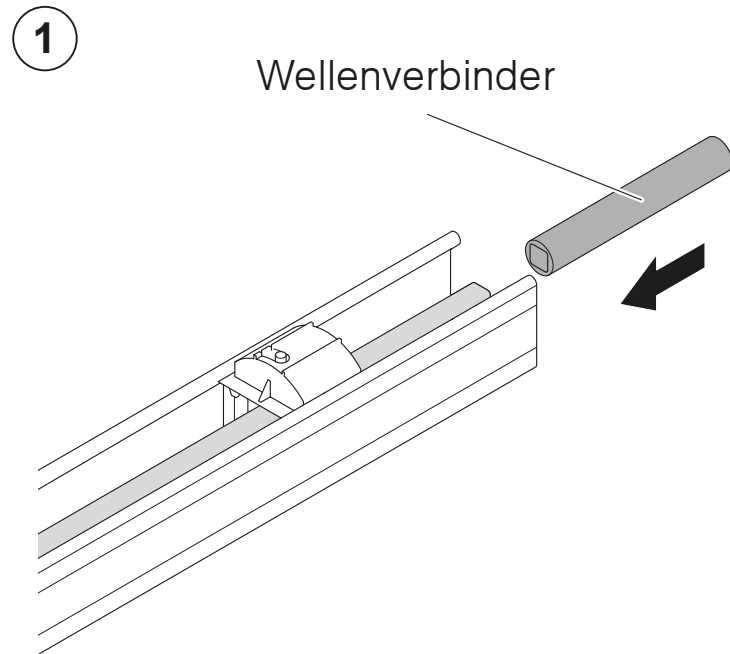

4

Führungsschiene befestigen

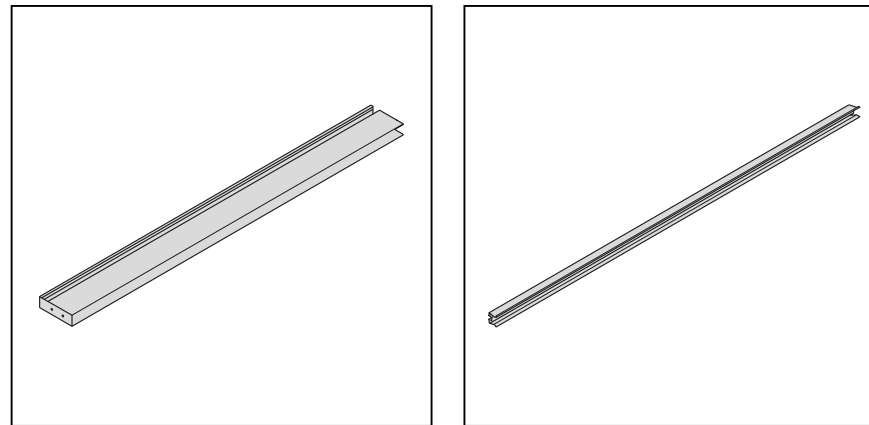

Montage- und Clipsprofil aus Führungsschiene entnehmen

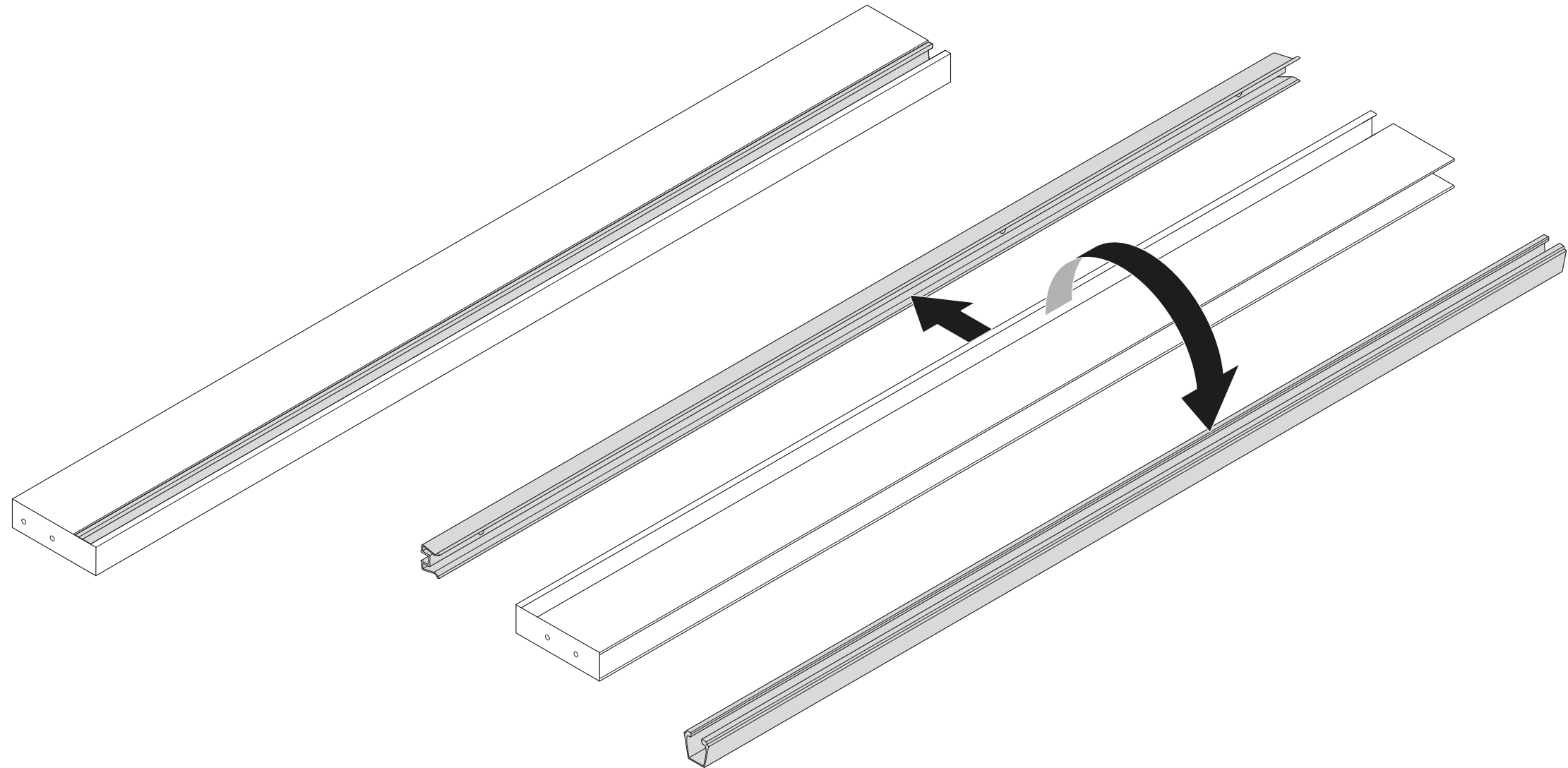

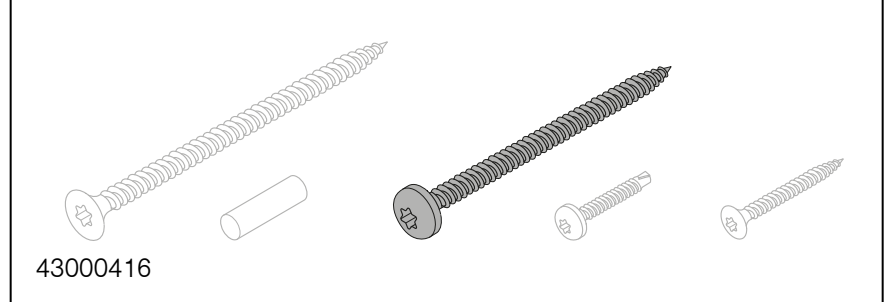

Mit Montageprofil:
Führungsschiene auf
Montageprofil

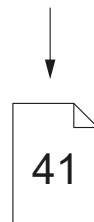
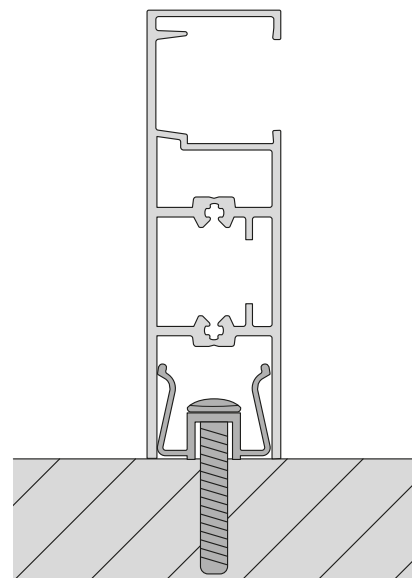

Mit Bohrungstyp A:
Führungsschiene nach
hinten verschraubt.

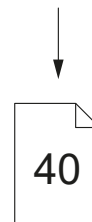
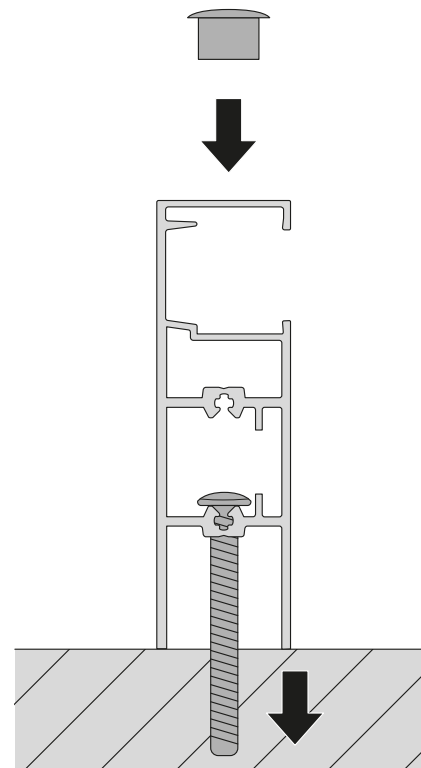

Mit Bohrungstyp B:
Führungsschiene seitlich zur
Laibung verschraubt.

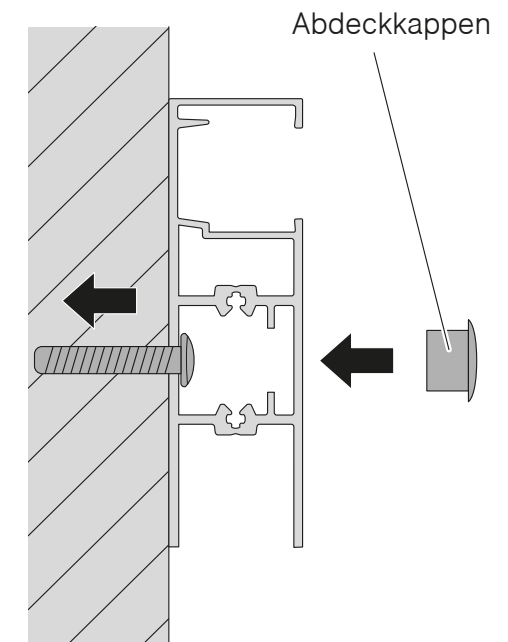

Befestigungsmöglichkeiten der Führungsschiene



Bei Verwendung der Distanzprofile oder Klinkeranschluss ist nur Bohrungstyp B möglich (siehe Seite 38).

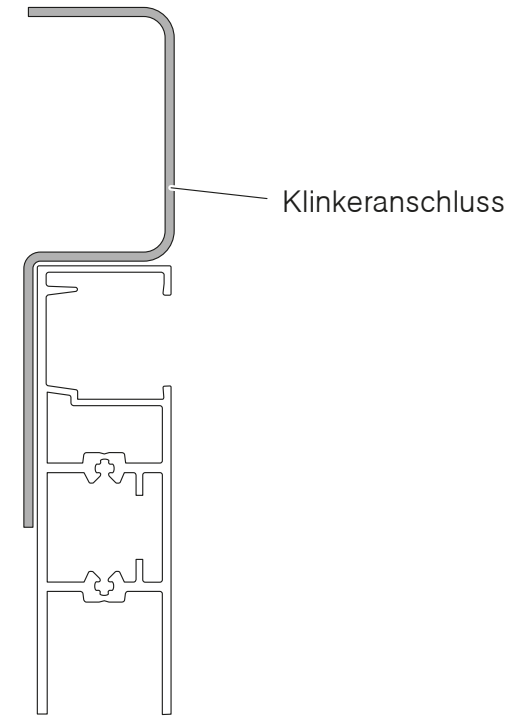
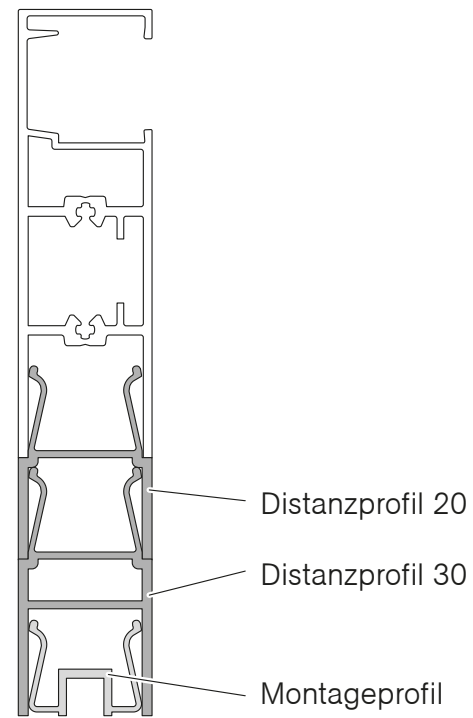

Führungsschiene befestigen



Nur vorgebohrte Löcher verwenden (Bohrungstyp A, B, siehe Seite 38)!

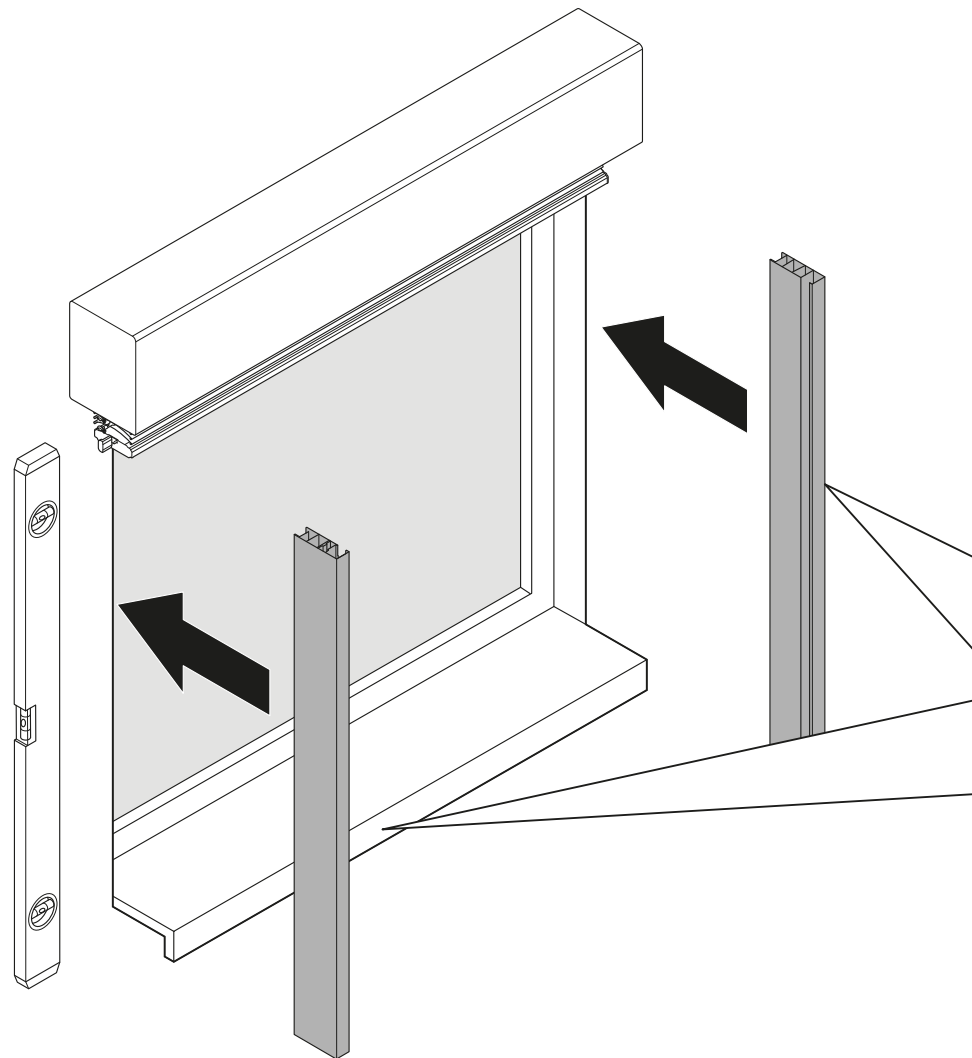

Blick 1

Blick 1

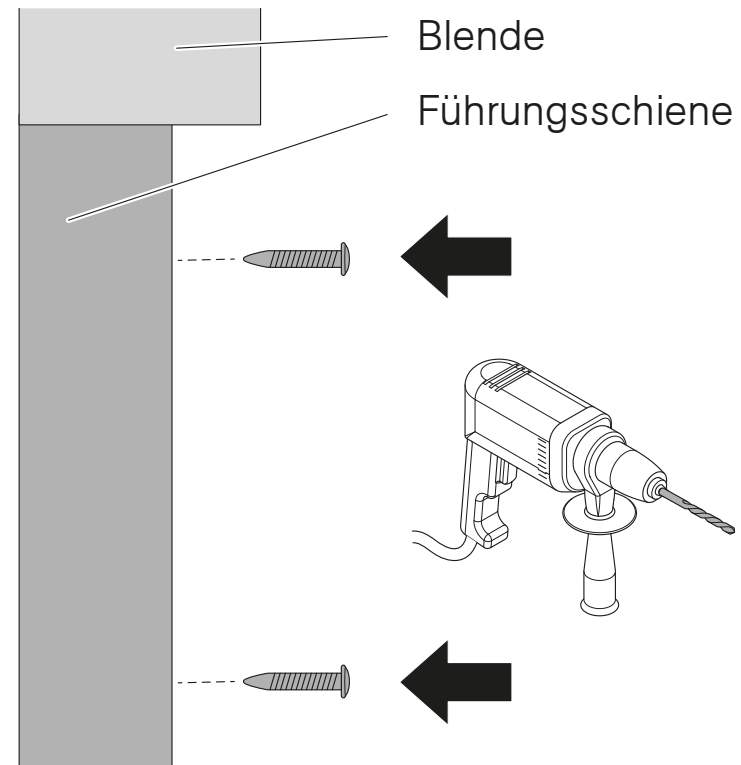

Ausführung mit Winkelblende

Ausführung mit U-Blende

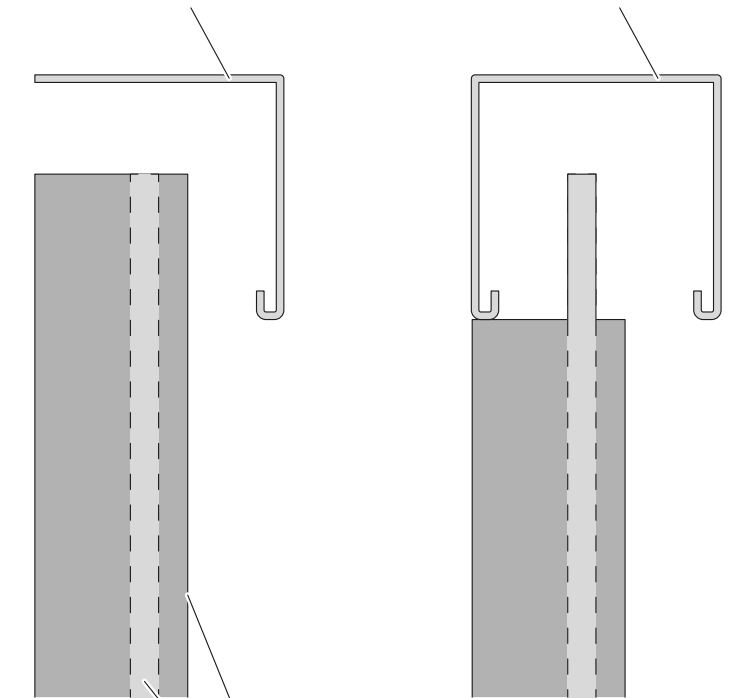

Führungsschiene
Clipsprofil

Montageprofil befestigen



Abstand Blende zu Montageprofil = 0 mm

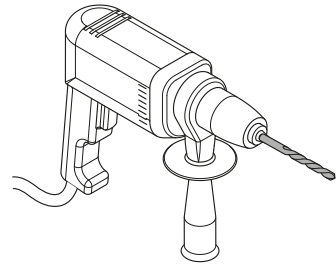

Nur vorgebohrte Löcher verwenden!

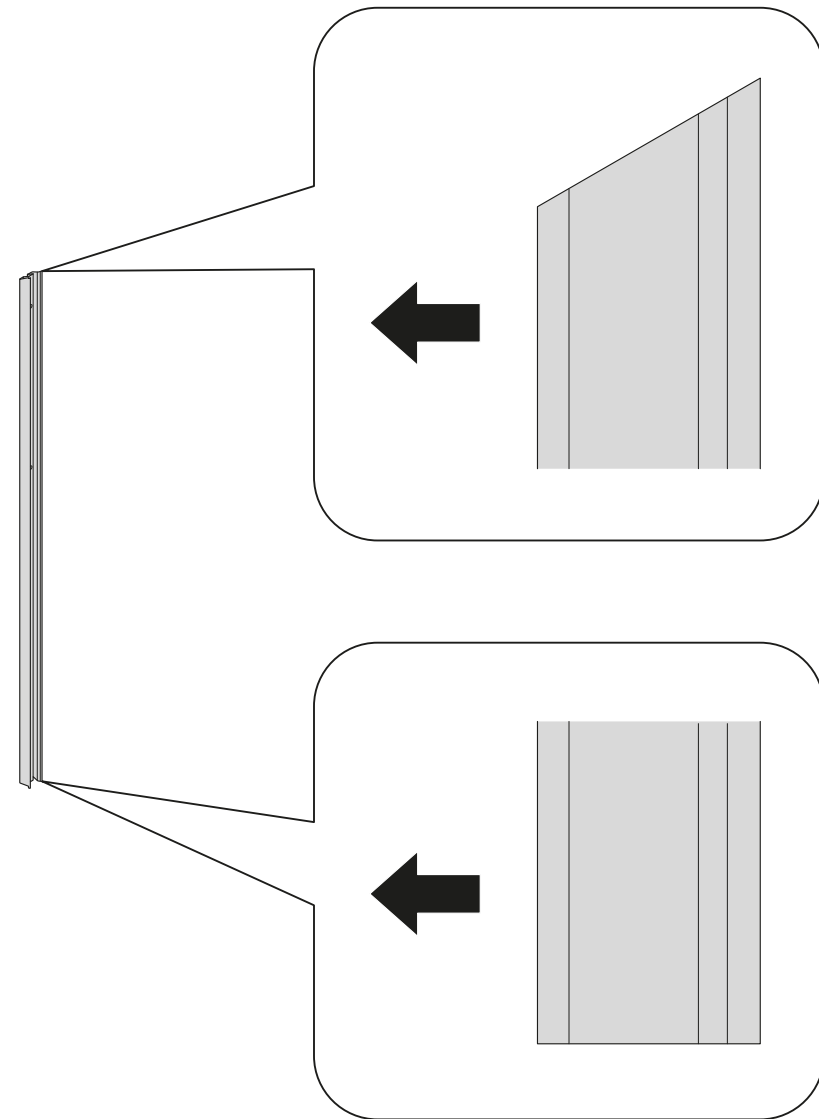
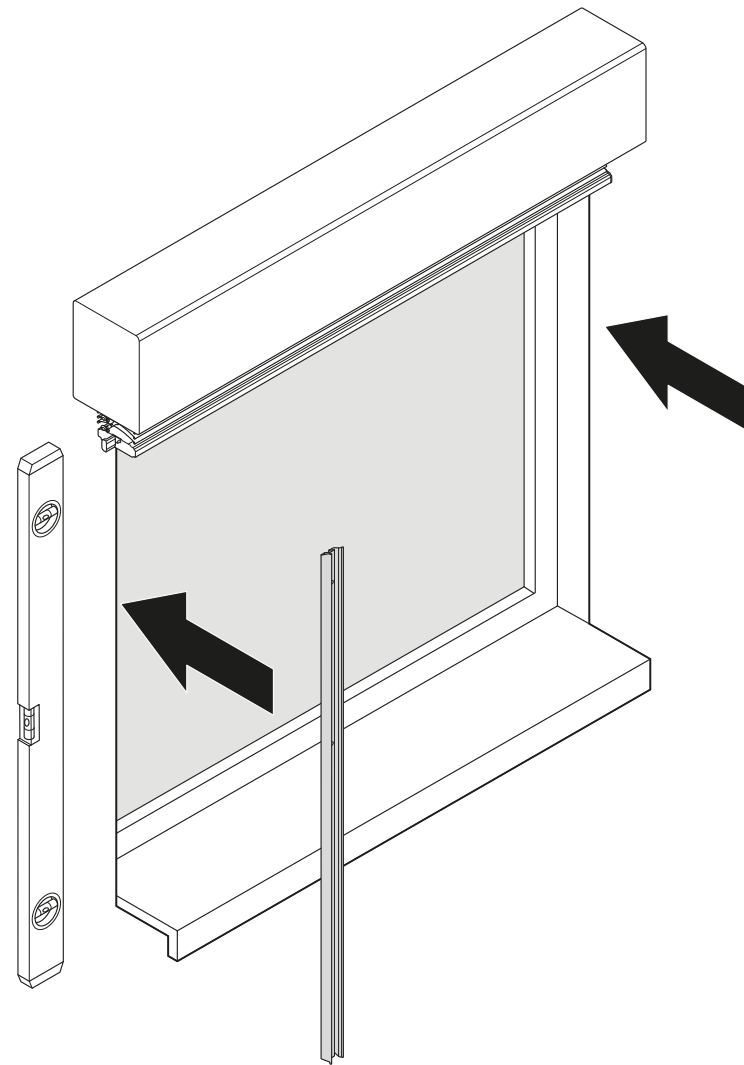

Führungsschiene aufs Montageprofil clipsen



Für Finger besteht Quetschgefahr!

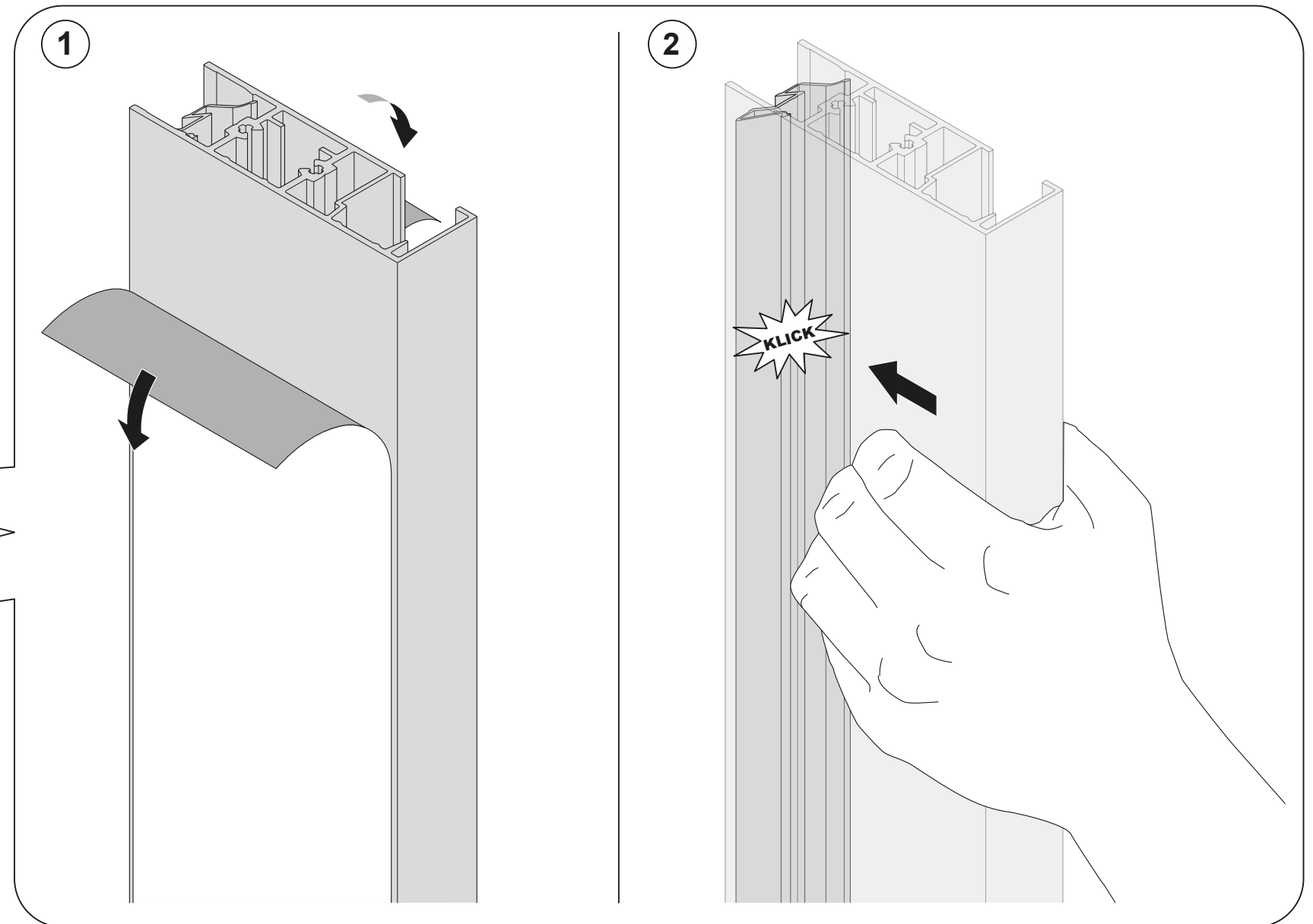
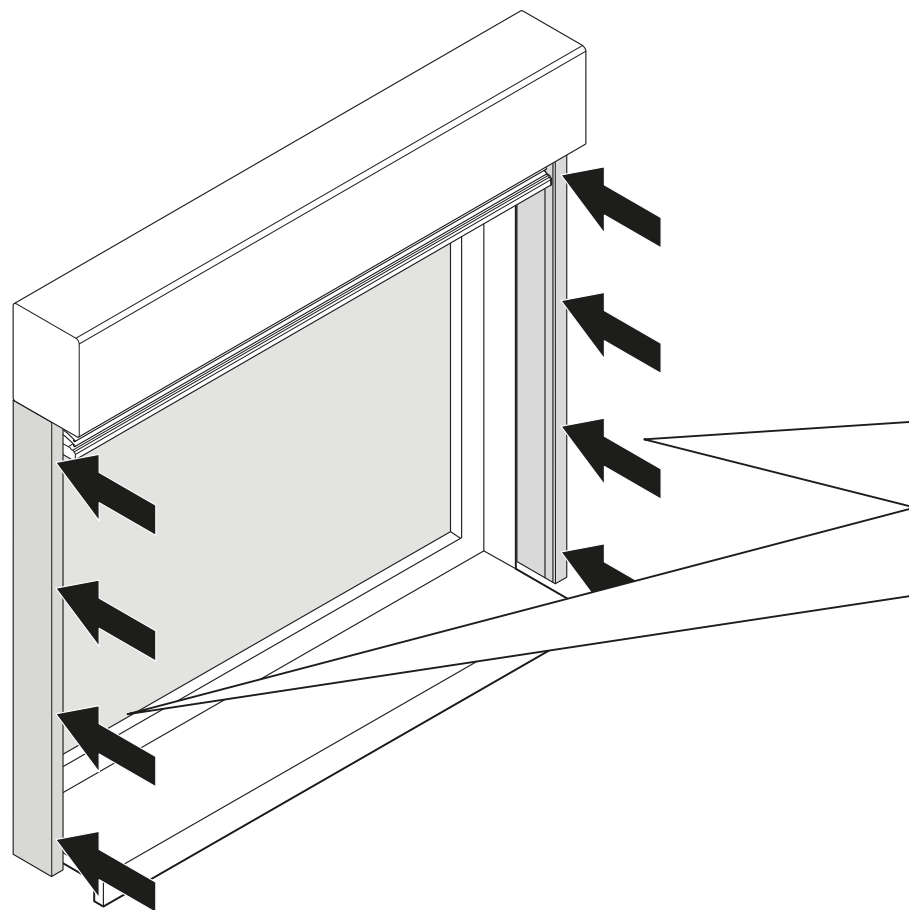

Sicherungsschraube anbringen (nur bei Montageprofil)

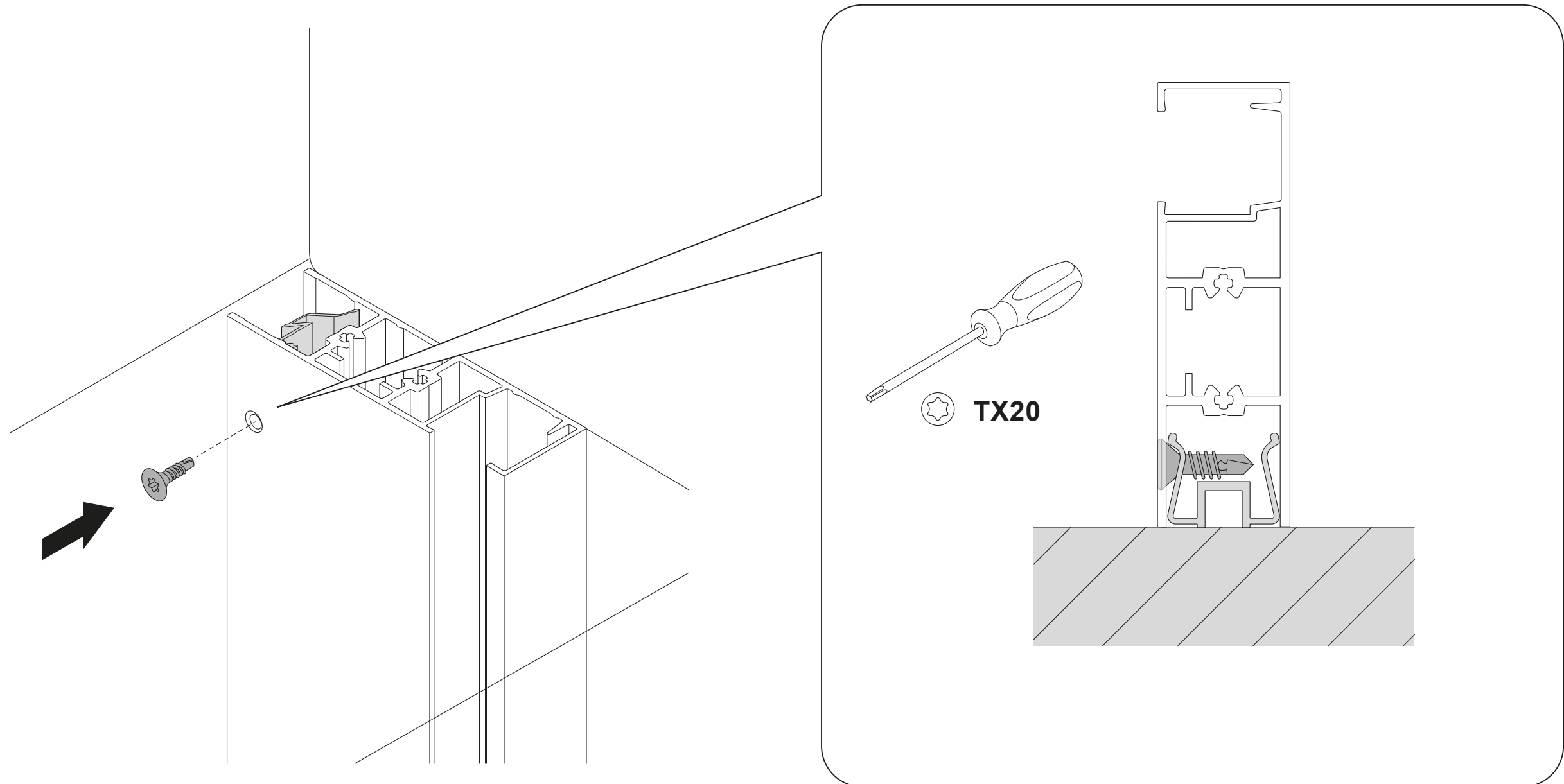

Clipsprofil einfädeln

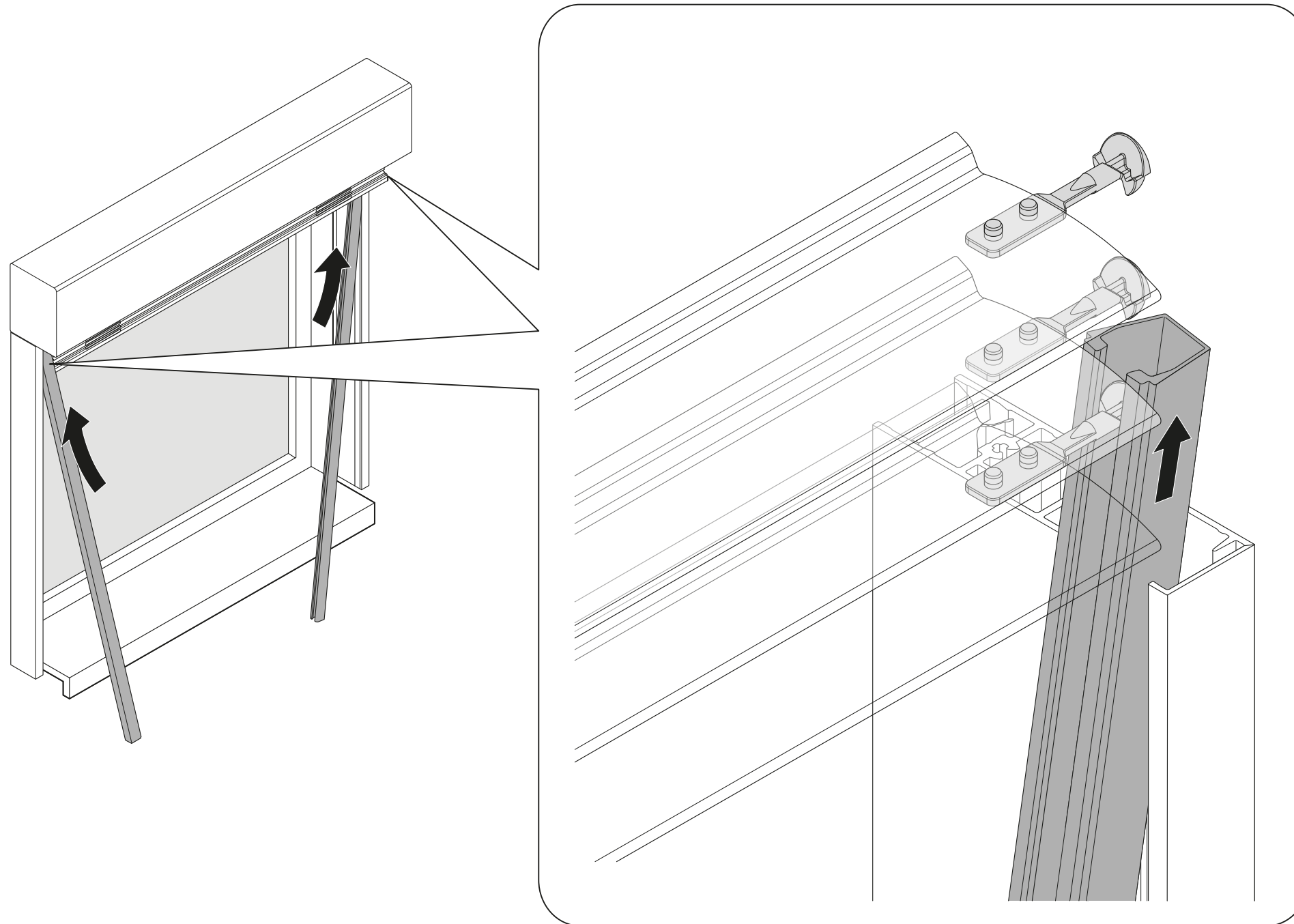

Clipsprofil einführen und in Führungsschiene einclippen



Für Finger besteht Quetschgefahr!

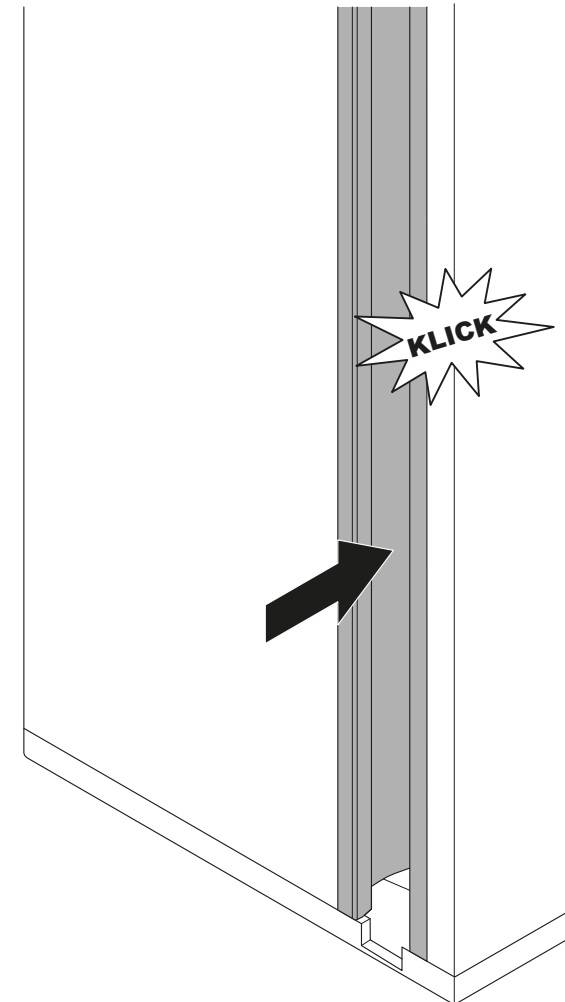
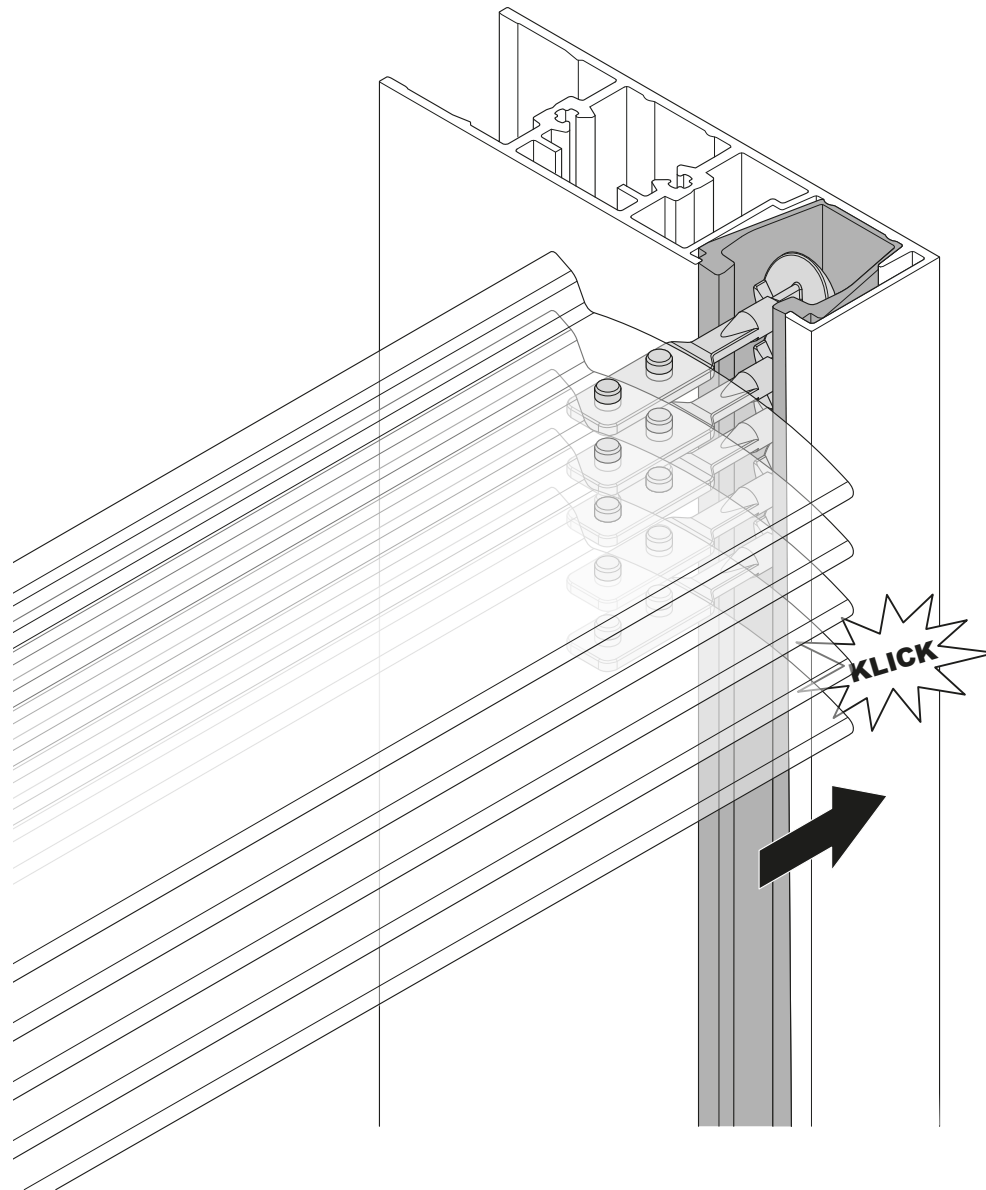

5

Kurbel anbringen

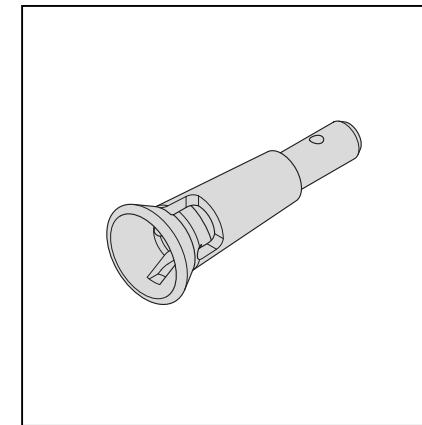
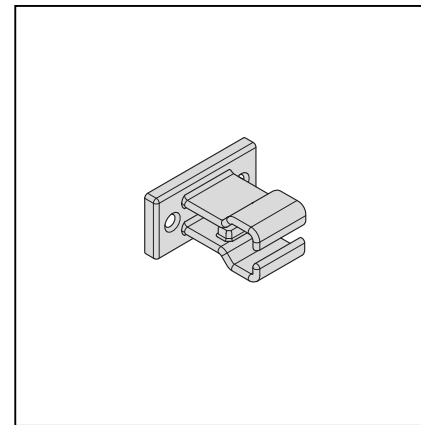
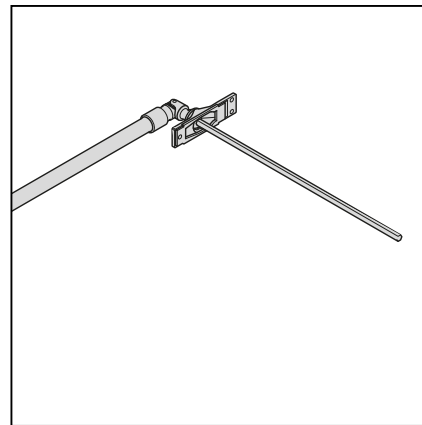

Kurbel anbringen

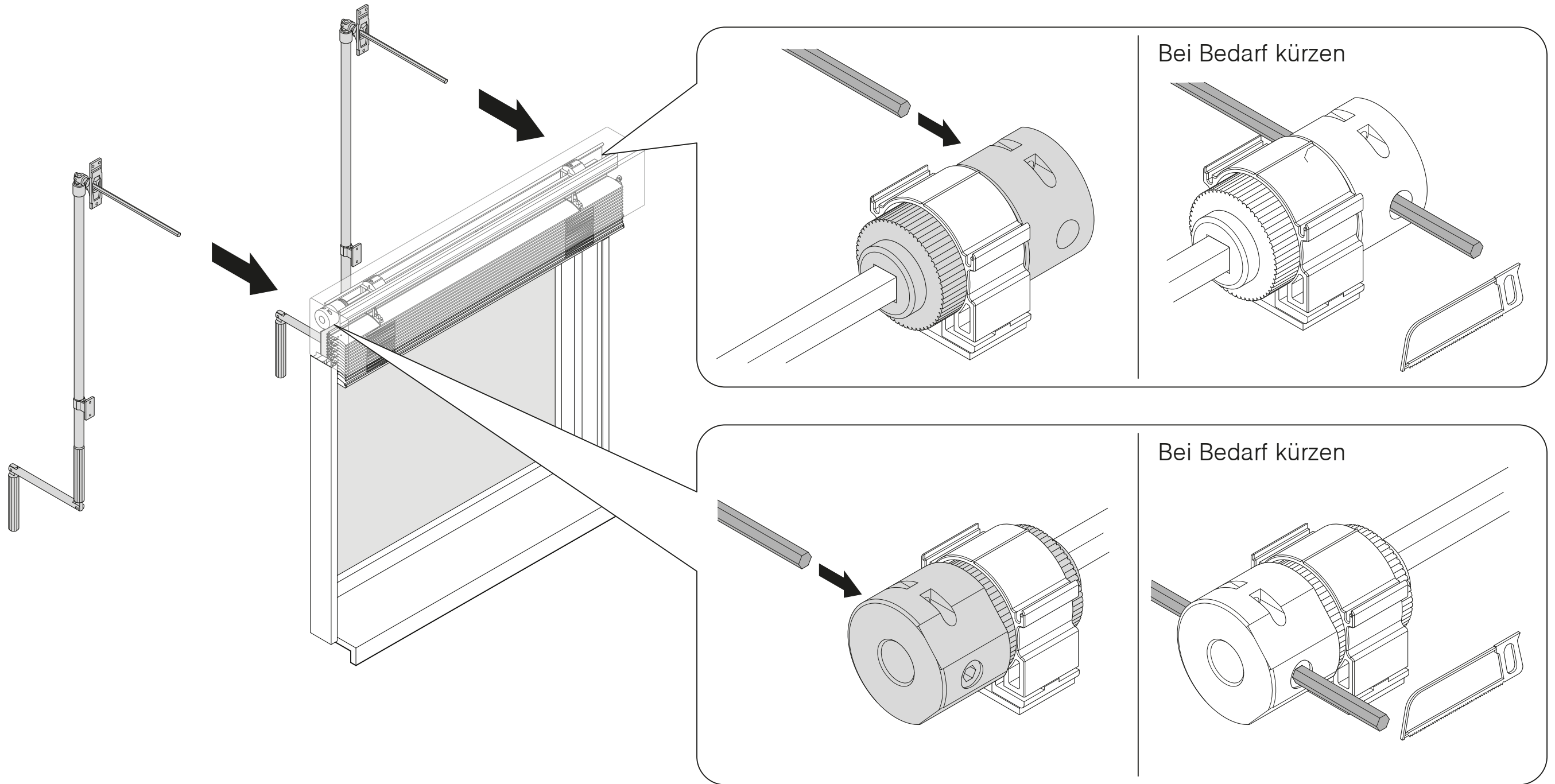

Kurbel anbringen

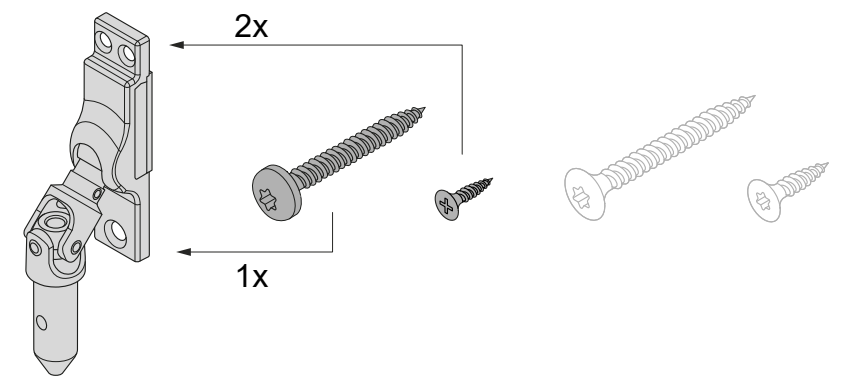
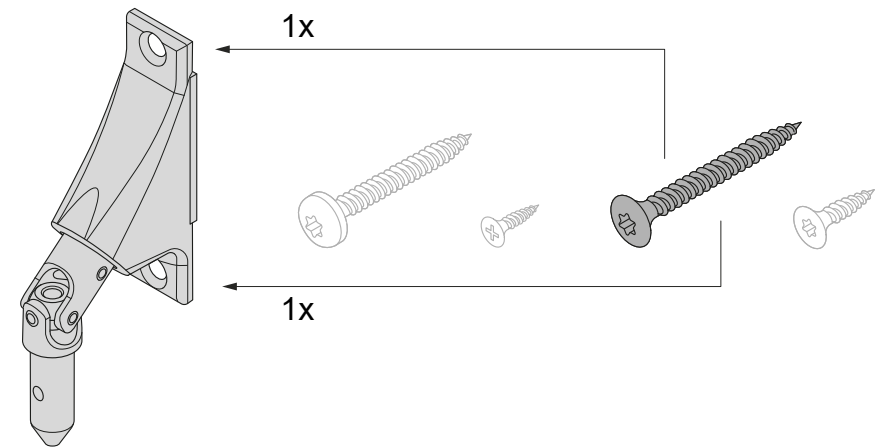
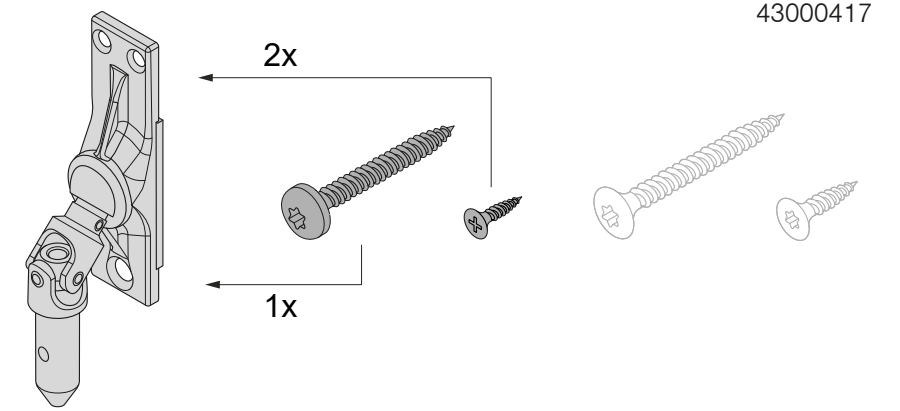
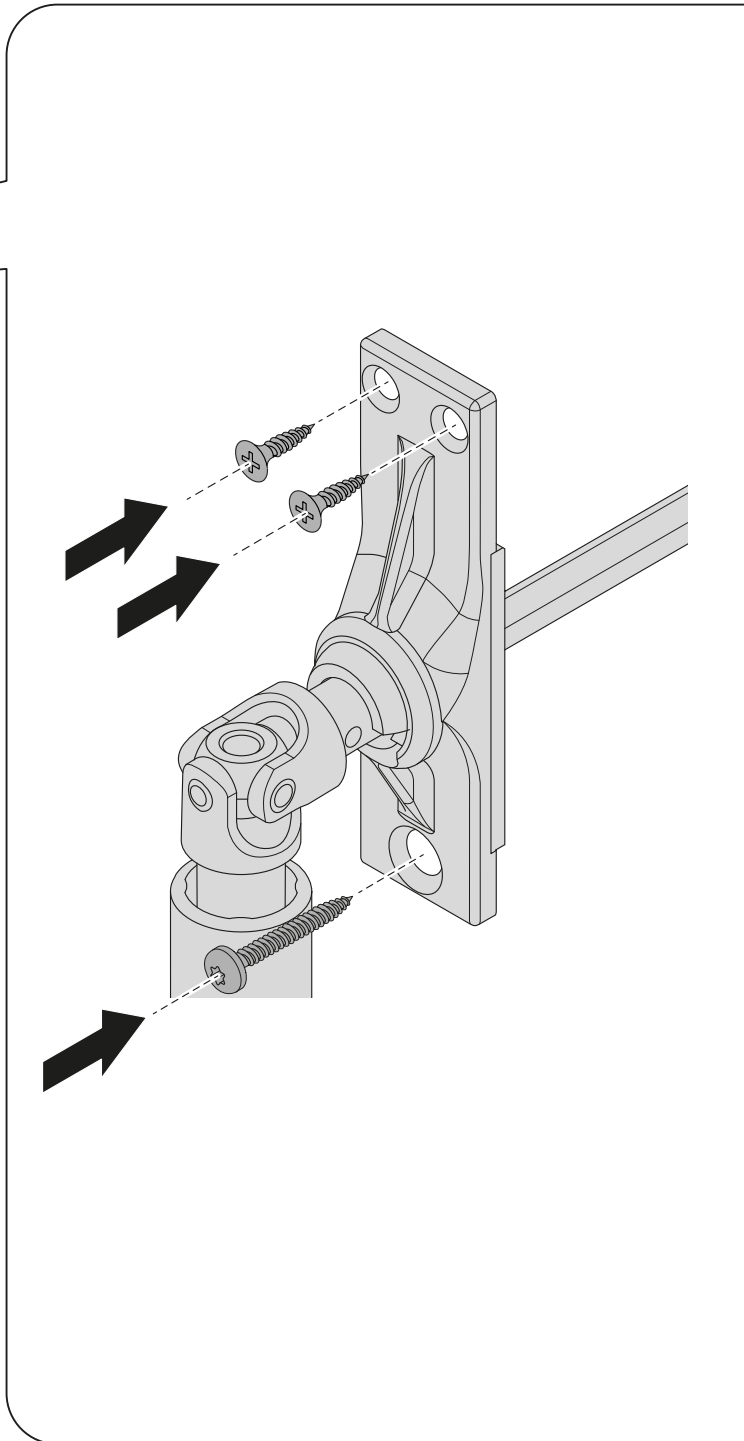
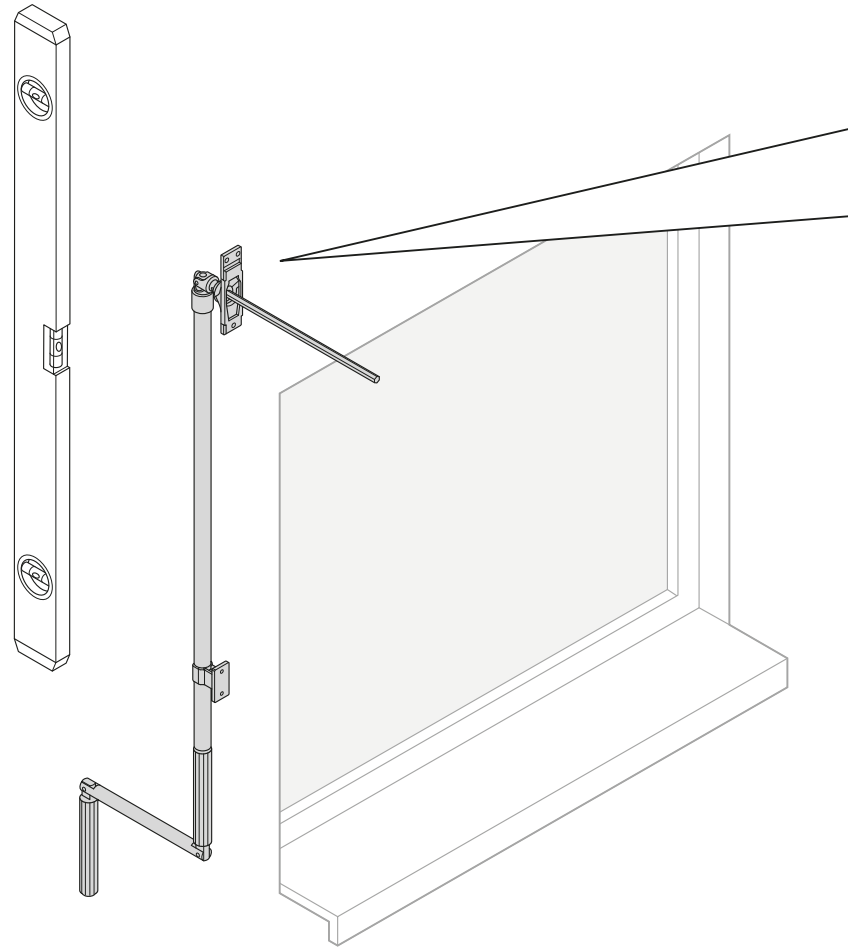

Kurbelhalter anbringen

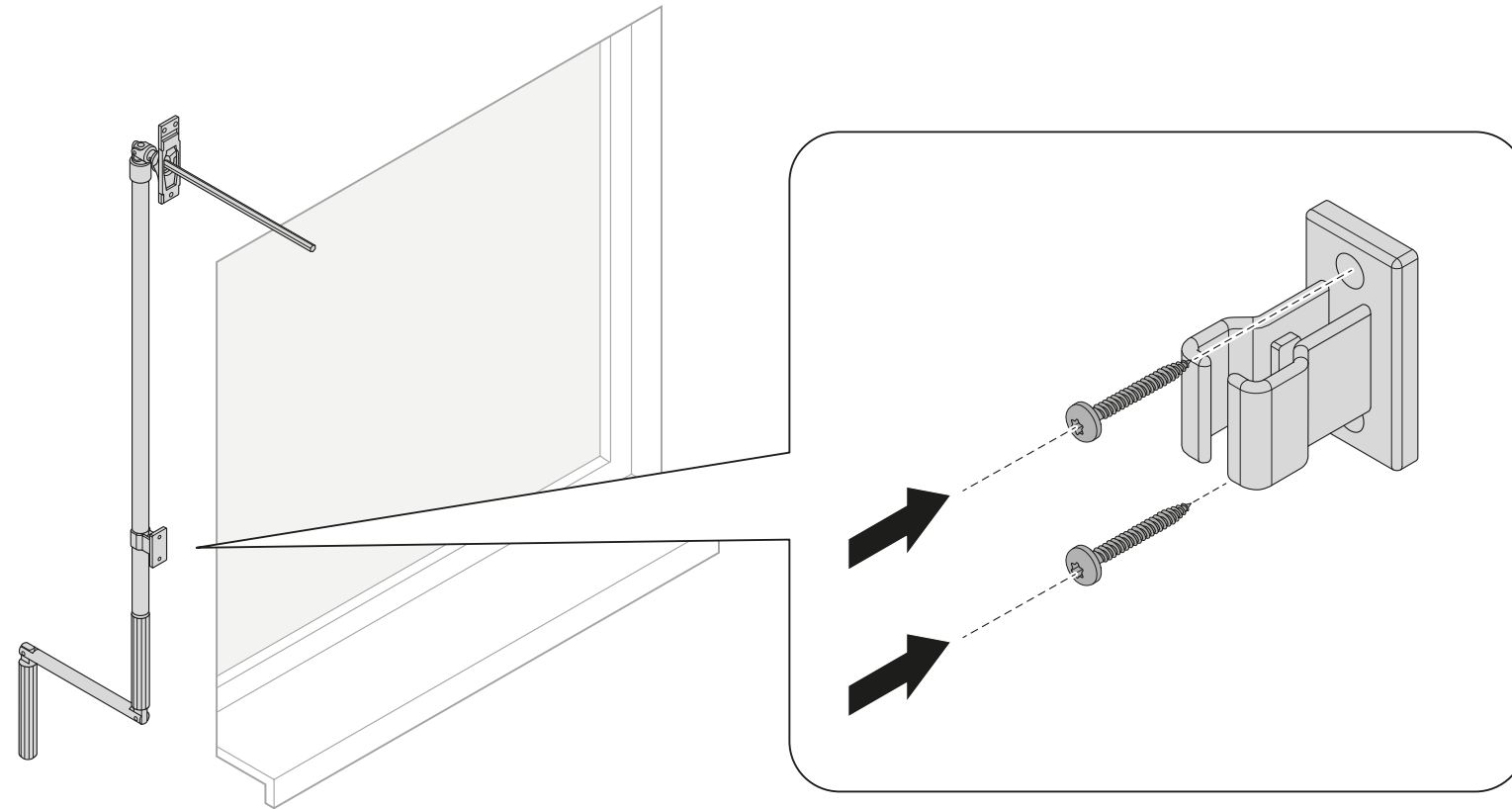
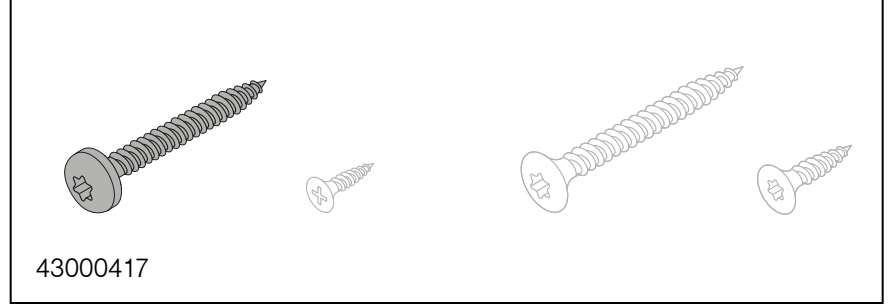

Optional: Kurbel mit abnehmbarem Trichter anbringen

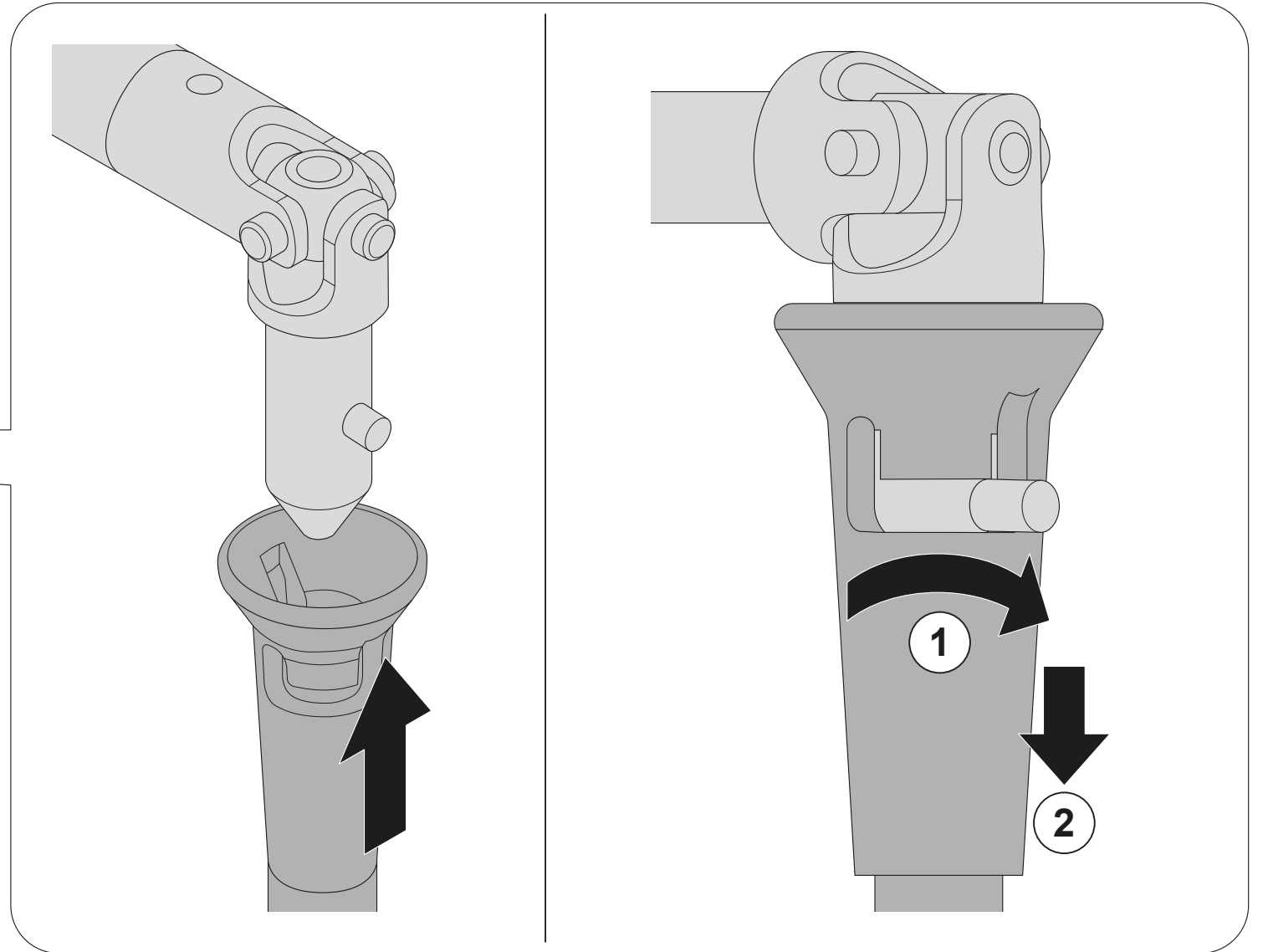
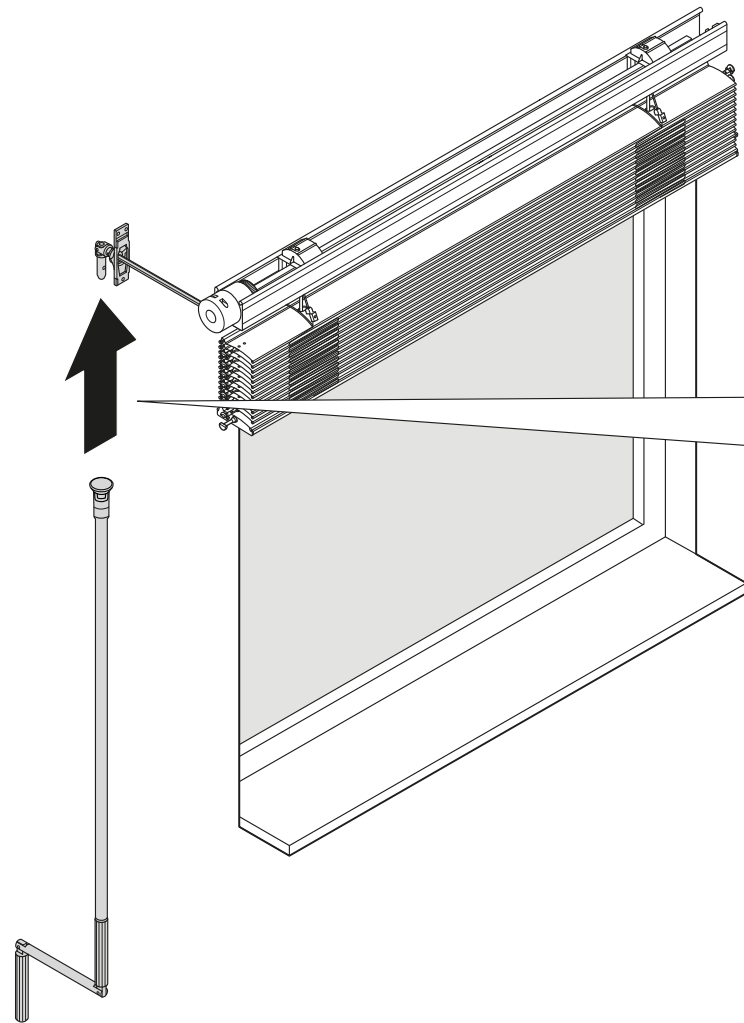

Lage des Kurbelgetriebes bei Bedarf anpassen



Achtung! Um den Raffstore gegen unkontrolliertes Herabfahren zu sichern, diesen komplett herablassen!

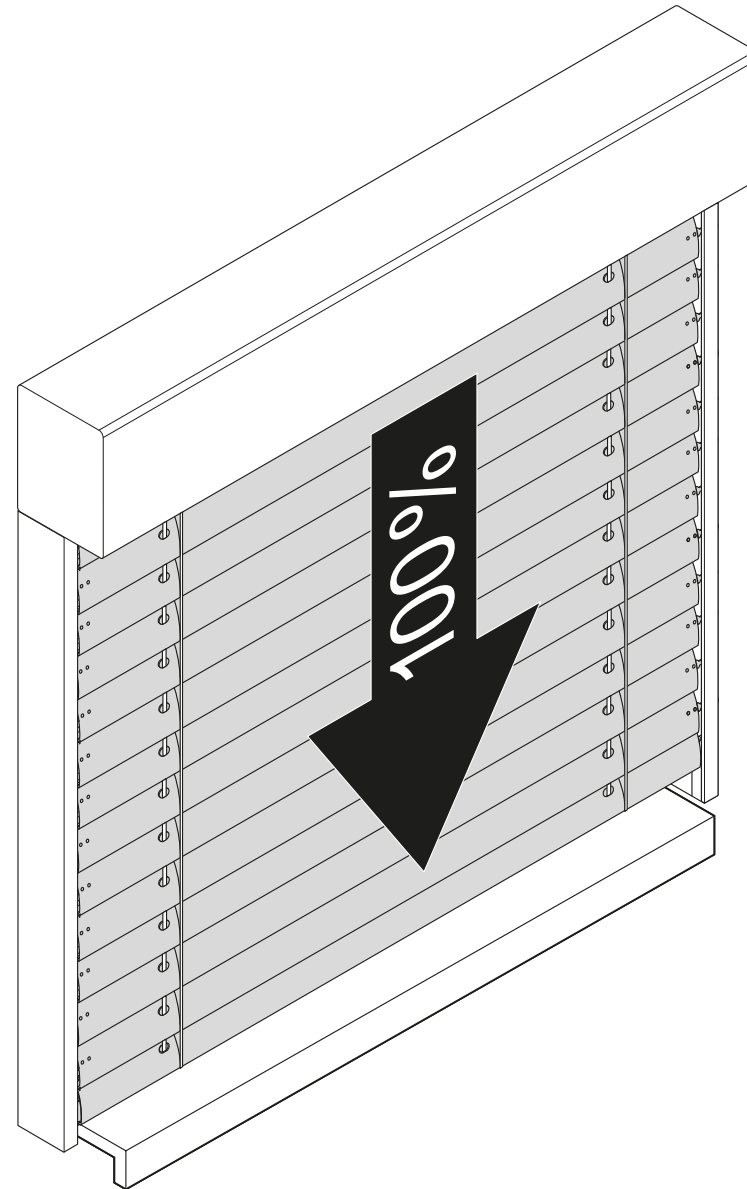

Lage des Kurbelgetriebes bei Bedarf anpassen

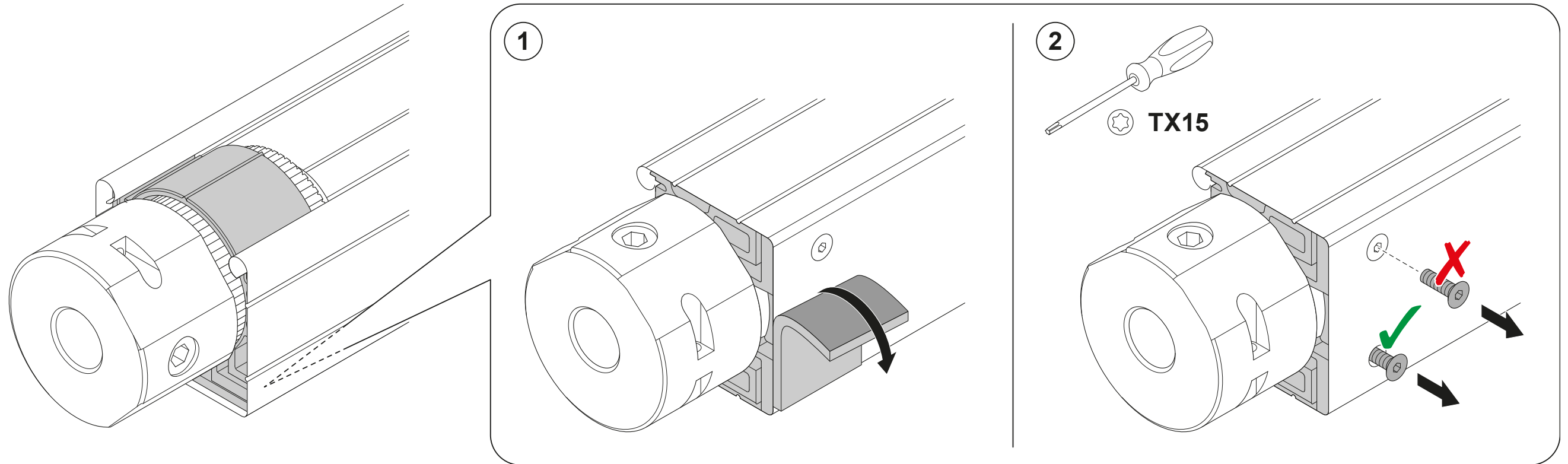

Lage des Kurbelgetriebes bei Bedarf anpassen (horizontal)

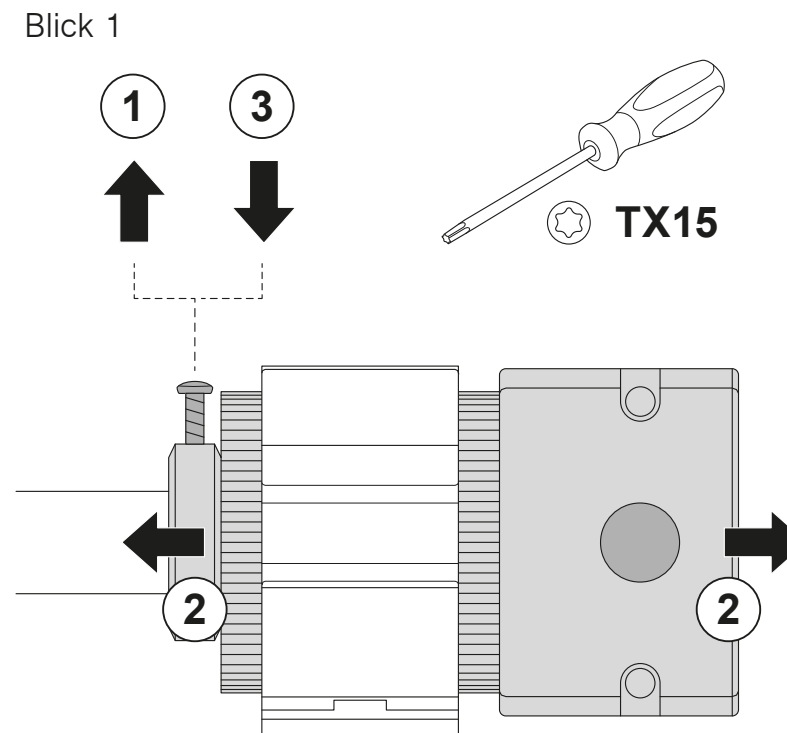
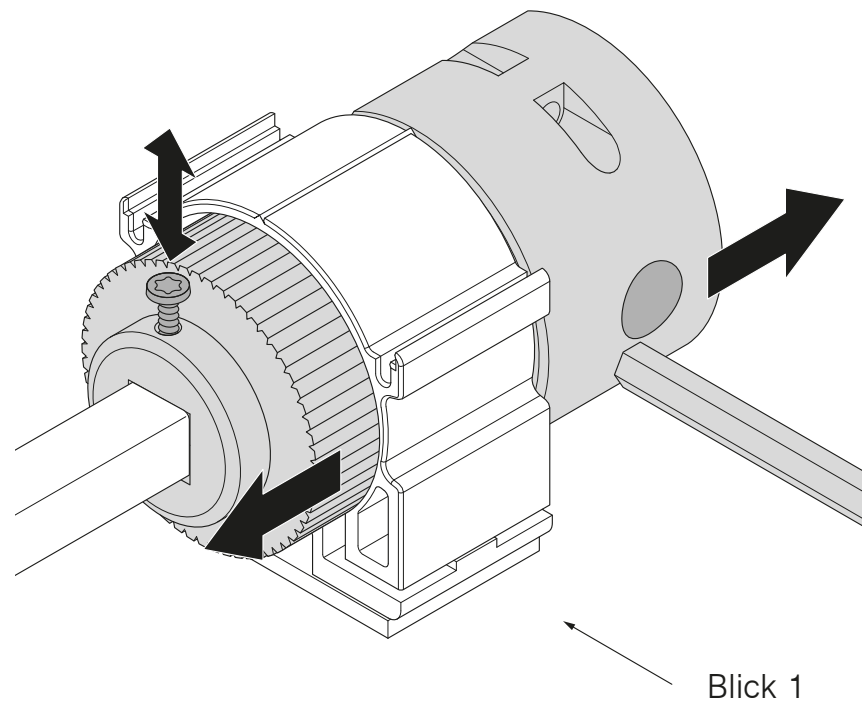

Lage des Kurbelgetriebes bei Bedarf anpassen (vertikal)



Antriebswelle vom Kurbelgetriebe trennen!

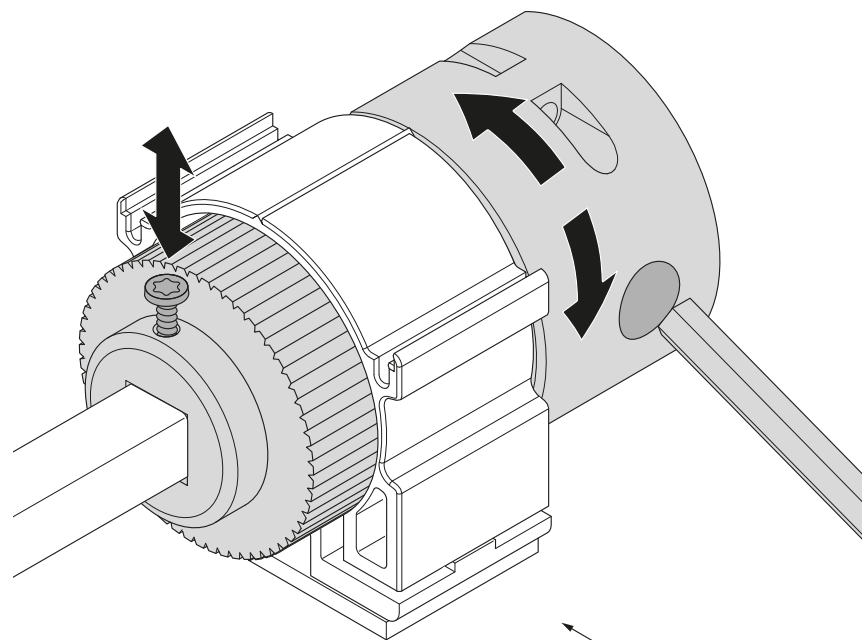

Blick 1

Blick 1

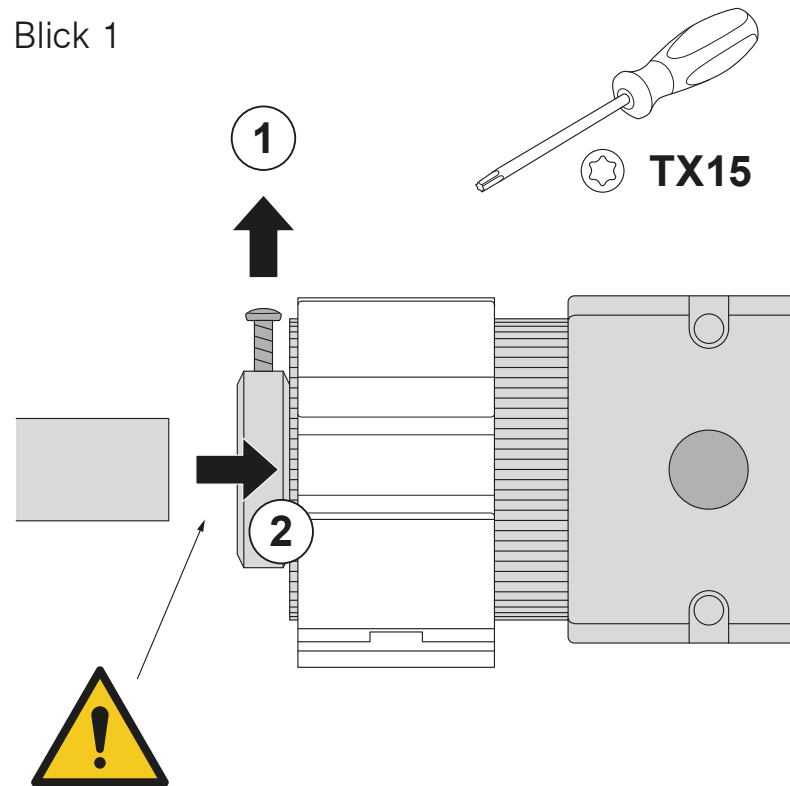

Blick 1

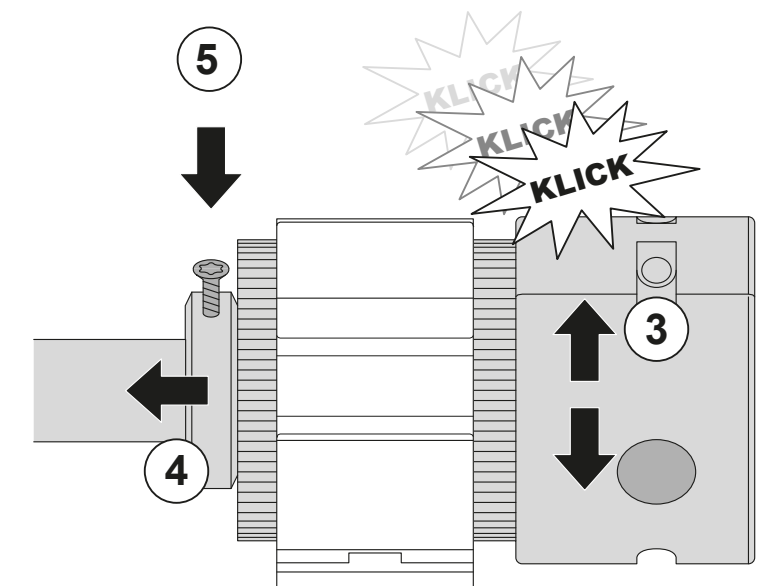

Lage des Kurbelgetriebes bei Bedarf anpassen

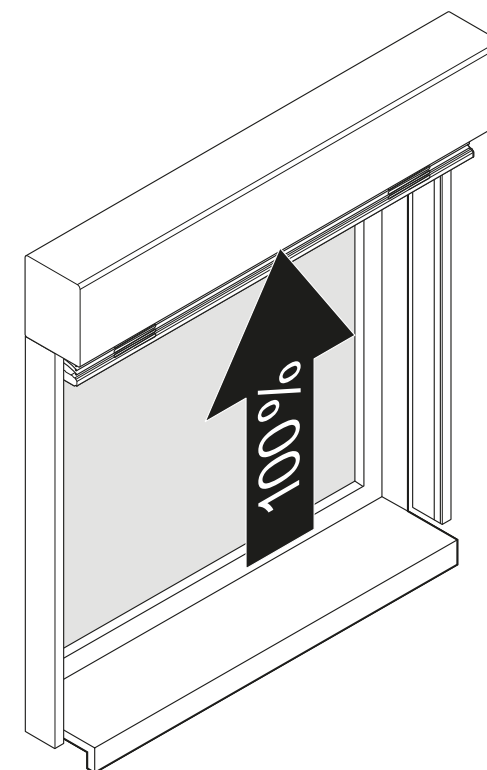
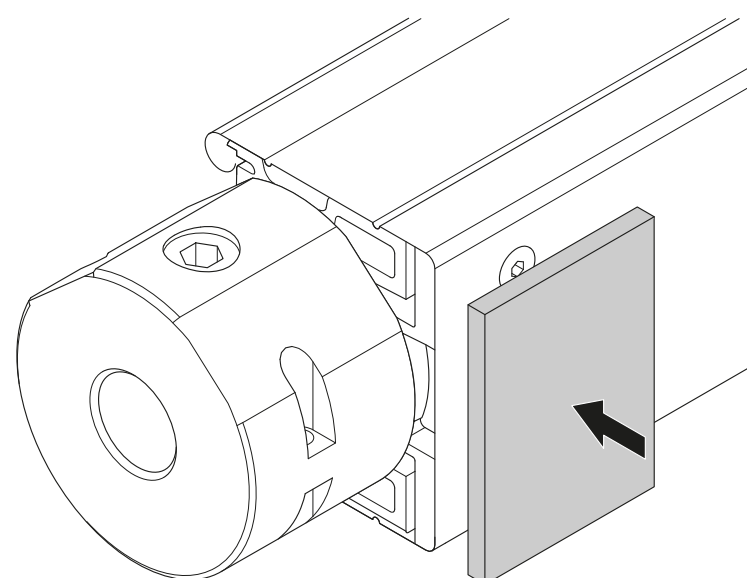
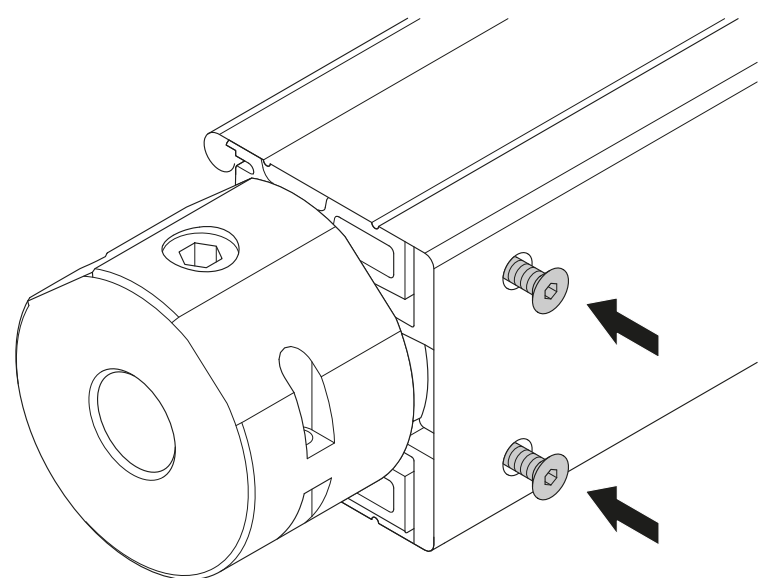

Test und Übergabe

Test	Beschreibung
1	Befestigungen auf festen Sitz prüfen.
2	Funktionskontrolle (Probelauf)
3	optische Kontrolle der Endlagen

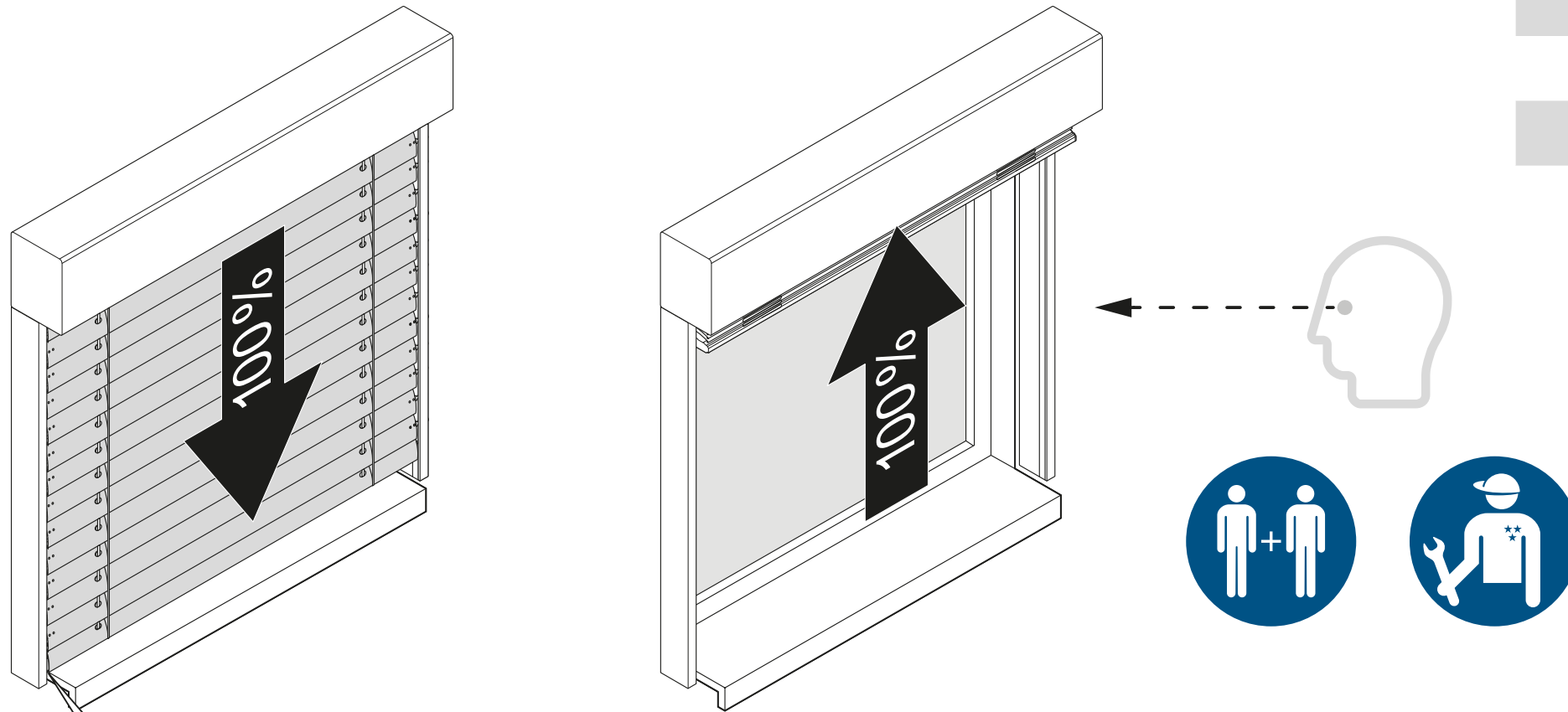

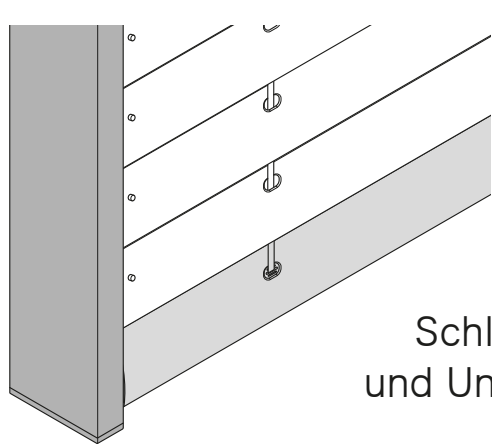

Unterschiene steht an der Fensterbank auf, Schließverhalten mit der letzten Lamelle nicht korrekt. X

Schließverhalten der letzten Lamelle und Unterschiene ohne Beanstandung, Unterschiene hängt frei. ✓

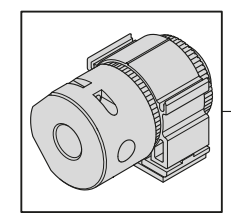

57

Bei Anlagen mit Spindelsperre

Bei Bedarf Endlagepunkte bei Anlagen mit Spindelsperre korrigieren

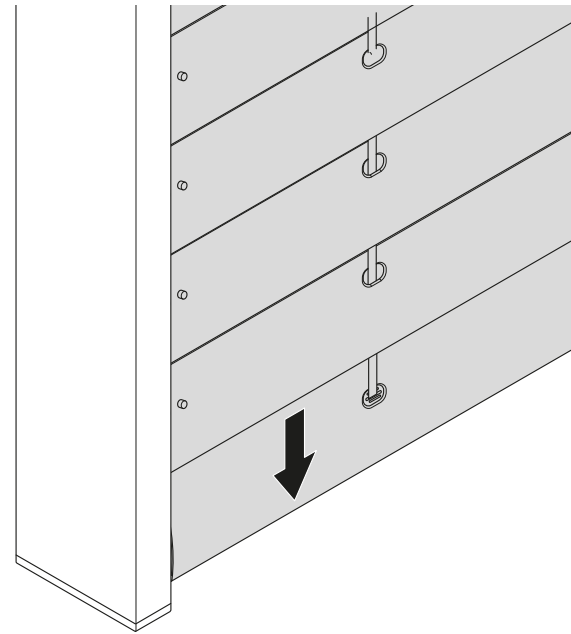
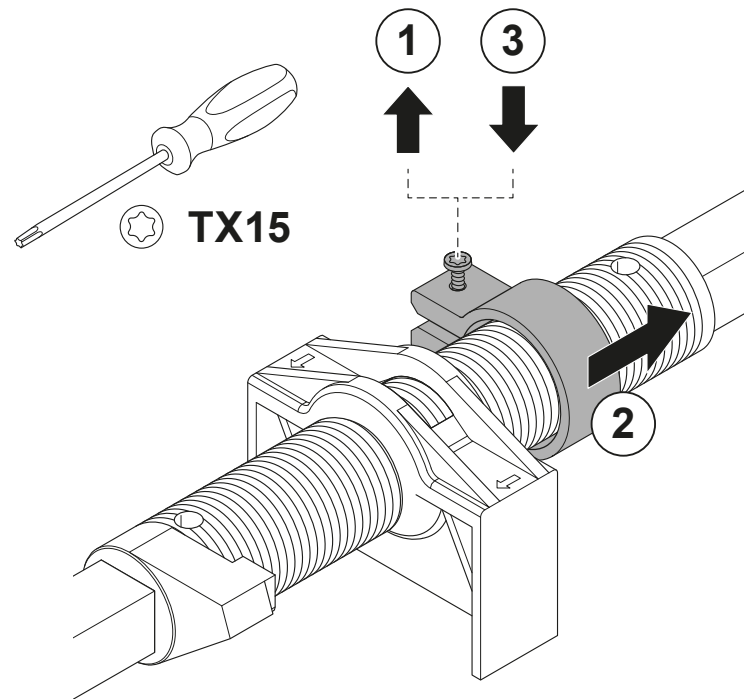

Die Endlagepunkte sind auf Bestellhöhe eingestellt. Ein Verstellen der Endlage kann zu Beschädigungen führen! Dies wird nicht durch die Gewährleistung abgedeckt.

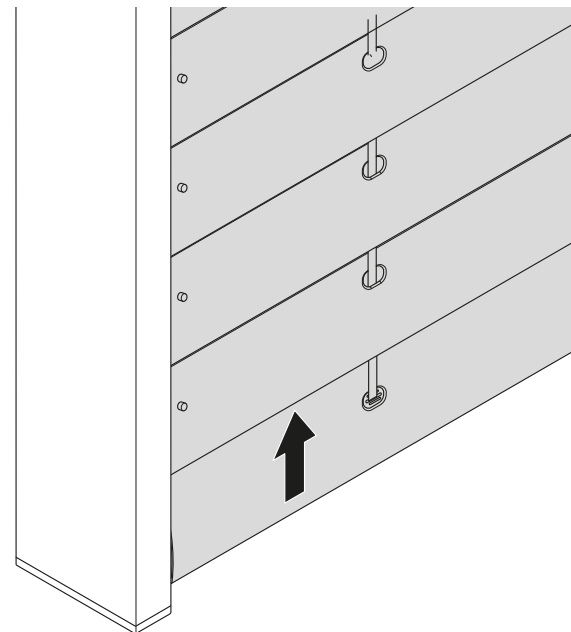
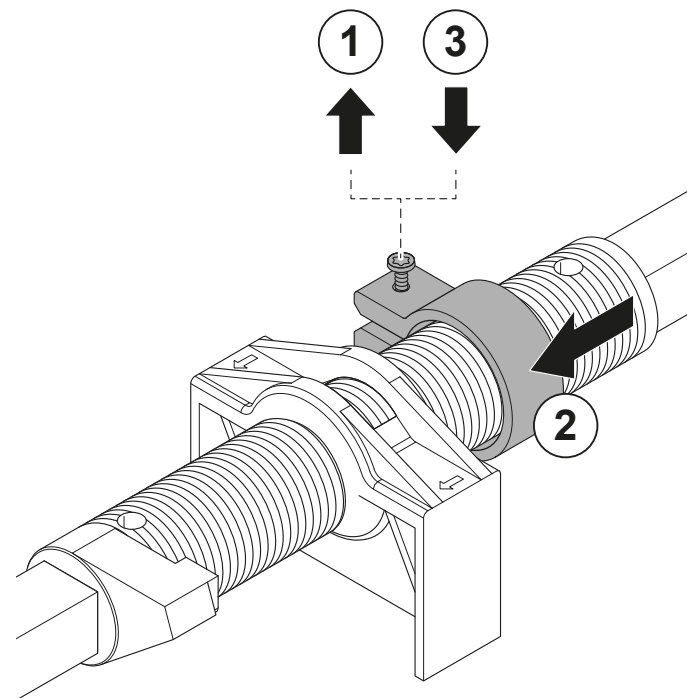

Onlineshop



Konfigurieren und bestellen Sie unser umfassendes Produktsortiment, Musterartikel und Werbemittel rund um die Uhr zu Ihren persönlichen Einkaufskonditionen.

Interaktive Bestellformulare



- » Bestellen Sie per interaktivem PDF-Formular.
- » lückenlose Eingabe dank vordefinierter Eingabefelder
- » ressourcenschonendes Arbeiten durch
Papiervermeidung
- » schnelleres Bearbeiten Ihrer Bestellung = kürzere
Lieferzeiten

REFLEXA-WERKE
Albrecht GmbH

Silbermannstraße 29
89364 Rettenbach

Tel.: +49 (0) 8224 999-0

Fax: +49 (0) 8224 999-222

www.reflexa.de

info@reflexa.de